

ISSUE 81 March 2006

CONTENTS

Editor

WordsWorth Writing

Assistant Editors

Jeanette Holland, Steve Ross

Graphic Designer

Katharine Hagan

Web Design

Lindy Gratton, Leanne McMahon,
Katharine Hagan

© Commonwealth of Australia 2006

ISSN 1035-9338

Geoscience Australia

GPO Box 378
Canberra ACT 2601 Australia
cnr Jerrabomberra Avenue &
Hindmarsh Drive.
Symonston ACT 2609 Australia

Internet: www.ga.gov.au

Chief Executive Officer

Dr Neil Williams

Subscriptions

Annette Collet
Phone +61 2 6249 9796
Fax +61 2 6249 9926
www.ga.gov.au/about/corporate/ausgeo_news.jsp

Sales Centre

Phone +61 2 6249 9966
Fax +61 2 6249 9960
E-mail sales@ga.gov.au
GPO Box 378
Canberra ACT 2601 Australia

Editorial enquiries

Len Hatch
Phone +61 2 6249 9015
Fax +61 2 6249 9926
E-mail len.hatch@ga.gov.au

The views expressed in *AusGeo News* are not necessarily those of Geoscience Australia, or the editors, and should not be quoted as such. Every care is taken to reproduce articles as accurately as possible, but Geoscience Australia accepts no responsibility for errors, omissions or inaccuracies.

Comment

2

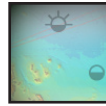

The northern Arafura Basin – a shallow water frontier

3

New research, along with previous exploration data, provides strong evidence for an active Palaeozoic petroleum system in this underexplored potential hydrocarbon province.

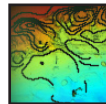

Bremer Sub-basin – a new deepwater petroleum opportunity

7

The recent completion of Geoscience Australia's Bremer Sub-basin Study heralded the first frontier exploration opportunity under the Australian Government's Big New Oil Program.

Clean or green – Nitrogen in temperate estuaries

10

Nitrogen input thresholds for nutrient enrichment identified.



Diatoms – keeping estuaries clean

12

Diatoms help maintain water quality by moving nitrogen into estuary sediments.

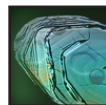

A time machine for Geoscience Australia

15

A new SHRIMP ion microprobe means improved geochronological support for mineral exploration in Australia.

Beating the big blows

18

New research assesses severe-wind risks.

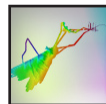

In Brief

20

Smart Exploration gets Geoscience Australia support

20

Geoscience Australia's impact modelling protecting Australia

21

New Chief for Minerals Division

21

Exploring the blind canyons of southwest Australia

22

Successful launch of ALOS satellite

22

Product news

23

Paterson Province gravity data released

23

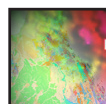

1:250 000 scale raster maps now online

24

Geology of Eastern Australia available as single dataset

25

Events Reports

25

Students experience geoscience

25



14th NSW Coastal Conference

25

Events Calendar 2006

26

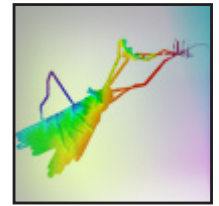
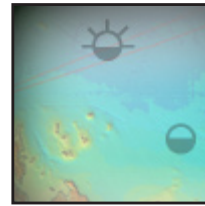
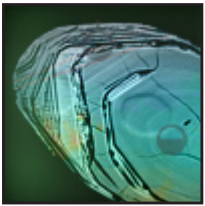

In this issue we bring you several reports on the progress of Geoscience Australia's 'Big New Oil' program, which provides pre-competitive information to support industry's search for new offshore oil provinces. Data and comprehensive interpretations from the first of the major new seismic acquisition programs—the Southwest Frontiers Survey—has recently been released and is available to explorers at the cost of transfer. This includes full coverage of the Bremer Sub-basin blocks included in 2005 acreage release areas. A recently completed sampling survey off southwest Australia also collected data which will assist in identifying the petroleum potential of the Mentelle Basin.

There is also a report on the northern Arafura Basin, a promising shallow-water frontier basin. The recently completed regional geological framework study and seepage study of the basin, in combination with previous results and data, provides strong evidence of an active Palaeozoic petroleum system.

This issue also reports on our work on Australia's coastal waterways. One article describes the role of diatoms small but dense phytoplankton in helping maintain good water quality. The second article uses our knowledge of nutrient dynamics (particularly nitrogen) to identify nitrogen inputs to various temperate estuaries, which will lead to nutrient enrichment and ecological change.

I am pleased to announce that Geoscience Australia will be installing a new sensitive high resolution ion microprobe (SHRIMP) in our headquarters next year. This in-house facility will revitalise our geochronology capability which provides the crucial time dimension of geological processes that form mineral deposits.

There are also reports on our contributions to research to protect Australia from natural disasters and mitigate their future impacts. The major cause of damage to residential buildings in Australia, as well as loss of life, is severe-winds such as cyclones, tornadoes and thunderstorms. Through analyses of the historical and geological record of severe-wind events in Australia, it will be possible to estimate the damage such winds are likely to cause and their impact on critical infrastructure. The potential of Geoscience Australia's tsunami impact modelling as the basis for emergency management response plans was successfully demonstrated at a workshop held in Perth in November. The workshop was part of the inaugural meeting of a committee set up by the Australian Emergency Management Committee to develop the emergency management elements of the Australian Tsunami Warning System.

New products reported on include: new gravity data covering the Paterson province of Western Australia, geology data covering the states of eastern Australia at 1:1 million scale as one dataset and the 1:250 000 scale national topographic raster maps which are the foundation for NATMAP Raster products.

Finally I am pleased to welcome Dr James Johnson as the new Chief of our Minerals Division. James brings to the position a wealth of experience in mineral exploration, mine geology, research management and leadership. His appointment will further strengthen the capabilities of Geoscience Australia's executive team.

Comment

Neil Williams

NEIL WILLIAMS
CEO Geoscience Australia



The northern Arafura Basin

– a shallow water frontier

New research, along with previous exploration data, provides strong evidence for an active Palaeozoic petroleum system in this underexplored potential hydrocarbon province.

Karen Earl, Graham Logan, Heike Struckmeyer and Jennifer Totterdell

The Australian Government's 2003-04 Budget included \$25 million to assist the petroleum exploration industry in the search for a new oil province by generating new geoscience data in offshore frontier areas and preserving Australia's seismic data archive. As part of this Big New Oil Program, Geoscience Australia is undertaking a program of seismic acquisition, geological sampling and oil seep detection studies in a number of Australia's frontier basins, including the Arafura.

Geoscience Australia in consultation with Industry, has identified the northern Arafura Basin as a promising shallow-water frontier and has recently undertaken a regional geological framework study and a seepage survey (figure 1). Together with previously published results and data, these studies suggest that the undrilled northern part of the basin has favourable conditions for the preservation of hydrocarbon accumulations, despite many risk factors.

Arafura Basin framework study

The goal of the framework study was to investigate the region's geology, which will underpin future petroleum exploration. This involved a comprehensive review and interpretation of all available existing well and seismic data. Outcomes of this new work will be published in two new Geoscience Australia records:

- 'New datasets for the Arafura Basin' is a compilation of a range of analyses by Geoscience Australia and collaborating agencies, and includes the results of new geochemical, organic-petrological, biostratigraphic and geohistory studies.
- 'Petroleum geology of the Arafura Basin' presents the interpretive results of the framework study, focusing on our new understanding of the evolution of the Arafura Basin and its petroleum potential.

Both will be available in mid-2006. In addition, the recently published audit of wells in the Arafura Basin (GA Record 2006/02) analyses petroleum exploration drilling in the basin to date, and summarises the available information on petroleum systems in the basin.

Arafura seepage survey

The Arafura seepage survey was conducted by Geoscience Australia in collaboration with the National Oceans Office in April and May 2005. This survey was part of Geoscience Australia's Seeps & Signatures project, which was initiated to identify and characterise features and signals of natural hydrocarbon seepage by integrating remote sensing and seabed and underlying geology with sampling and analytical programs (figure 1).

The survey collected a variety of acoustic datasets (multibeam swath, echo sounder, side-scan sonar, sub-bottom profiles, seismic) and included an extensive sampling program of sediments, rocks, biological material, conductivity-temperature-depth (CTD) profiles, and video imagery. The acoustic dataset was used during the survey to map out appropriate sites for sampling using dredges, gravity cores, benthic sleds and sediment grabs.

The survey collected over half a terabyte of digital data, over 100 cores, 90 grabs and 50 camera deployments. Details of the survey, with initial interpretations of selected datasets, are presented in a post-survey report to be available in mid-2006.

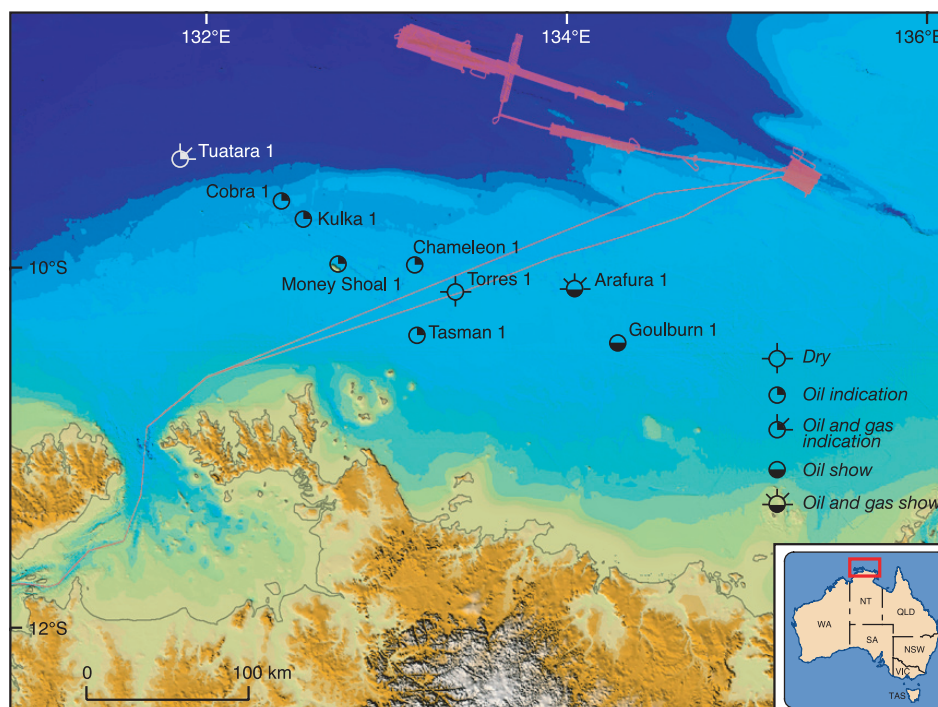

◀ **Figure 1.** Location map of study area and seepage survey tracks. Wells drilled previously in the Arafura region are shown.

Arafura Basin geology

The Arafura Basin is a Neoproterozoic to Palaeozoic basin, extending in shallow waters (< 220 m) from onshore northern Australia into Indonesian waters. It is in a structurally complex region with an underlying Proterozoic basin (the McArthur Basin) and an overlying Mesozoic to Recent basin (the Money Shoal Basin; figure 2).

The structure of the Arafura Basin is dominated by the northwest-trending, highly deformed Goulburn Graben. All exploration drilling in the basin has been restricted to this area, where large structures combined with a thick sedimentary section (up to about 10 kilometres of Arafura Basin sediments) provided exploration targets. Geoscience Australia's study has revealed that the area to the north and east of the Goulburn Graben (the 'Northern Platform') also contains thick sediments (figure 3), but is less deformed. This area offers a wide range of different play types for exploration.

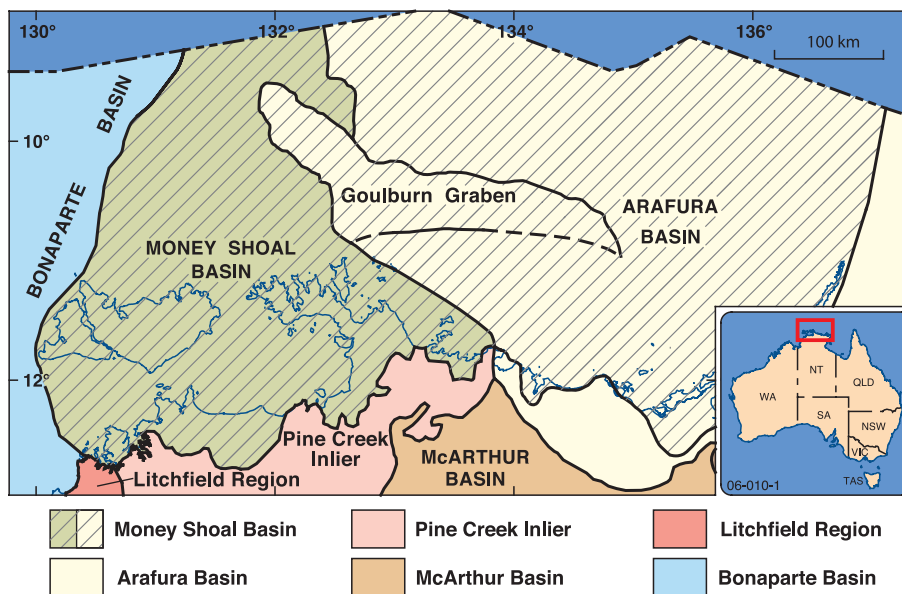

▲ Figure 2. Regional setting of the Arafura, McArthur and Money Shoal basins.

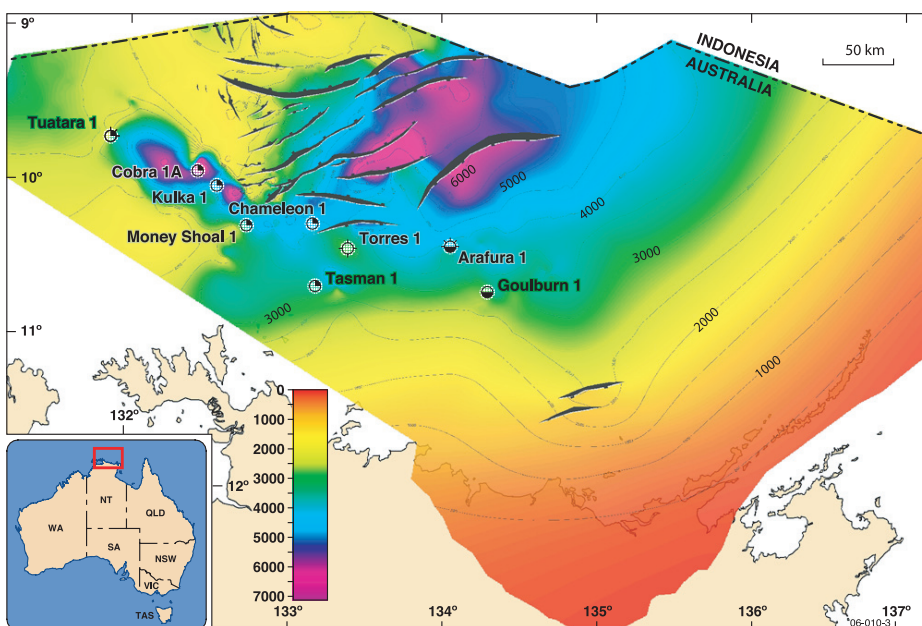

◀ Figure 3. Sediment thickness map (in milliseconds two-way time) of the Arafura region, showing well locations in the Goulburn Graben and the distribution of Neoproterozoic faults.

Goulburn Graben prospectivity

Exploration in the Goulburn Graben began in the early 1970s, with the drilling of Money Shoal-1. Since then, there have been two other main periods of exploration—the early 1980s, and late 1980s to early 1990s—with a total of nine wells drilled to date (figure 1). A recent audit of wells by Geoscience Australia (GA Record 2006/02) attributed the lack of commercial success in the Goulburn Graben to a combination of poor-quality reservoirs and/or restricted fluid movement, hydrocarbon charge, timing of events and breach of structure.

Despite these exploration risks, hydrocarbon generation and migration in the Goulburn Graben is evidenced by oil and gas shows at Arafura-1 (figure 4) and an oil show at Goulburn-1. These shows have been linked geochemically to a potential Cambrian source rock. Other potential source rocks are present throughout the Palaeozoic and Mesozoic succession. Palaeozoic reservoirs intersected in the Goulburn Graben area are generally of poor quality, but may improve laterally with changes in sediment facies and secondary porosity development. Irrespective of this, the overlying Mesozoic sediments of the Money Shoal Basin contain high-quality reservoirs that are well placed to receive charge from Palaeozoic source rocks. Both the Arafura and Money Shoal basins contain a number of potential seals. The Bathurst Island group forms a laterally and vertically extensive regional seal and generally overlies the high-quality Mesozoic reservoirs.

Many of the petroleum system elements recognised in the Goulburn Graben are likely to be present in the undrilled northern region of the basin.

Northern Arafura Basin prospectivity

The northern part of the Arafura Basin is characterised by a series of large Neoproterozoic half grabens, bounded by generally northeast-trending planar normal faults (figure 3). The overlying Palaeozoic section seems structurally conformable, despite the long hiatuses indicated by unconformities at the base of the Cambrian, Devonian and Carboniferous–Permian sections (figure 5). Compared with the Goulburn Graben, which was the focus of extensional tectonism in the Late Carboniferous – Early Permian and was subsequently highly deformed during a mid-Late Triassic compressional episode, the Northern Platform has undergone only minor deformation (figure 5). Mild reactivation of the Neoproterozoic faults during Triassic compression resulted in the formation of both small and large-scale inversion anticlines and uplift of the basin margins. As a result, many of the risk factors for the accumulation of hydrocarbons identified in the Goulburn Graben are reduced in this region. Trap breach and reservoir degradation in the Goulburn Graben is largely associated with the Triassic structuring and erosion event. There, erosion of up to 3.5 kilometres of Palaeozoic sediments breached early formed traps, and hydrothermal alteration reduced reservoir quality. However, in the northern part of the basin, early formed traps are likely to have remained intact, negating trap breach and timing issues, and reservoir quality is probably much higher, with less hydrothermal alteration and shallower burial.

Recent geohistory studies by Geoscience Australia model hydrocarbon generation and expulsion; it was not limited to the Palaeozoic era, but also occurred in the Late Cretaceous to Cenozoic. This implies that traps in the region may have accumulated oil and gas at various stages of basin development.

Evidence that hydrocarbon generation and expulsion have occurred in the northern Arafura Basin is provided by Infoterra's 2003 Global Seeps study of the region, which suggests the possible presence of oil seeps. Additionally, bright amplitudes imaged by seismic data at various stratigraphic levels may indicate hydrocarbons in the section (figure 6).

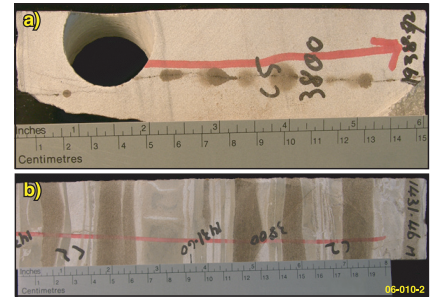

▲ **Figure 4.** Evidence for oil generation at Arafura-1: oil staining in Ordovician (a) and Devonian (b) rocks.

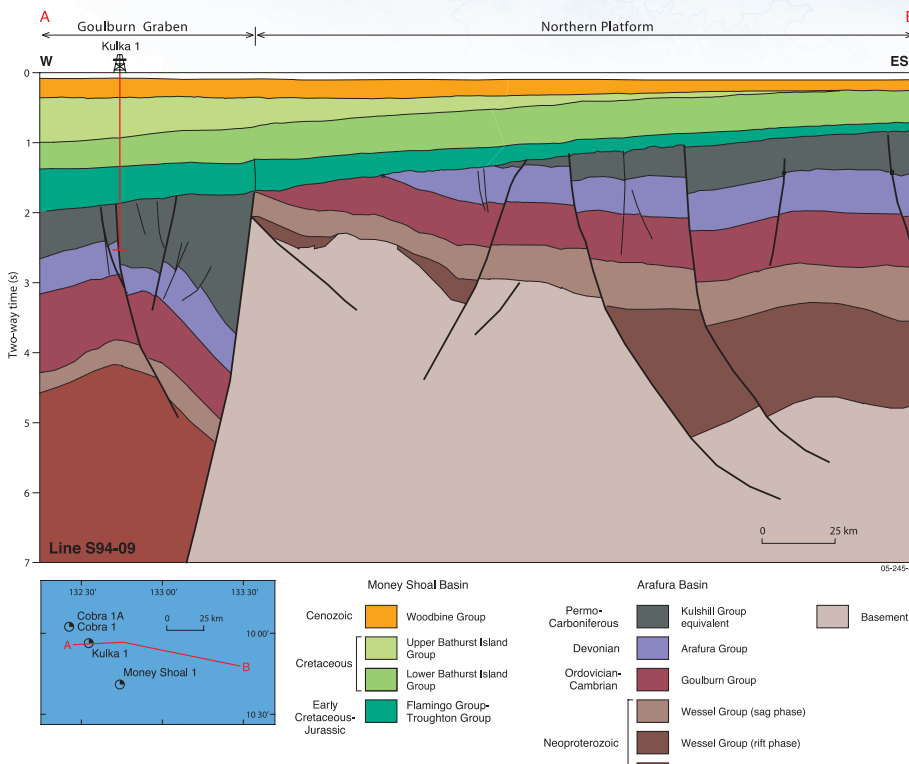

▲ **Figure 5.** Regional cross-section from the Goulburn Graben (Kulka-1) to the Northern Platform.

Initial results from interpretation of a range of geophysical attributes within the sub-bottom profile data (collected during Geoscience Australia's seepage survey) and deep seismic data show a range of features that are indicative of the presence of hydrocarbons in the northern and northeastern basin. For example, high amplitudes near the tips of Cenozoic reactivation faults that affected Palaeozoic strata correspond to low frequencies in seismic data and nearby synthetic aperture radar (SAR) anomalies. Numerous enhanced reflectors with reversed polarity and low frequency indicative of shallow gas were observed on sub-bottom profiles (figure 6). Echosounder data revealed a possible active gas plume similar in character to a confirmed plume on the Yampi Shelf in the Browse Basin. Sidescan sonar data showed extensive pockmark fields coincident with an areally extensive 'poor seismic data zone' that may be due to the presence of shallow gas (figure 6).

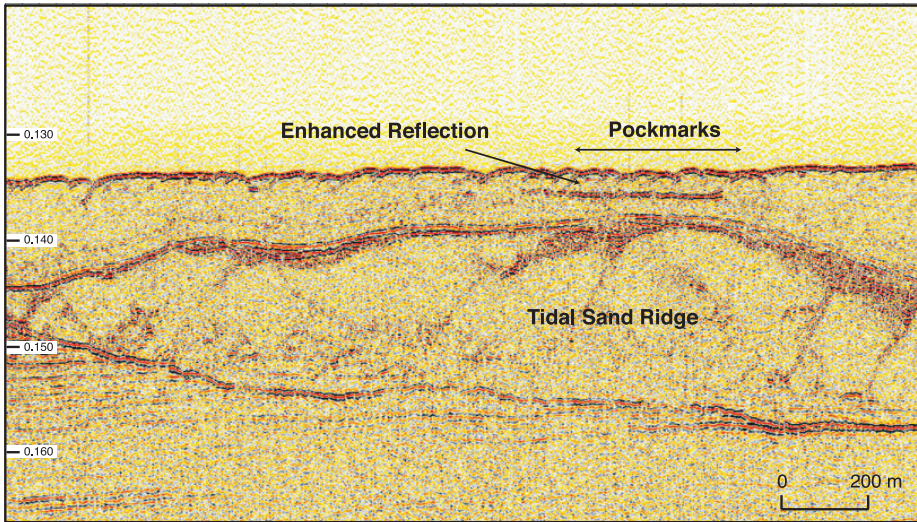

◀ **Figure 6.** Tidal sand ridge with an enhanced reflector (reversed polarity) above the highest point. This, together with the pockmarked seabed above, is a possible indication of vertical gas migration.

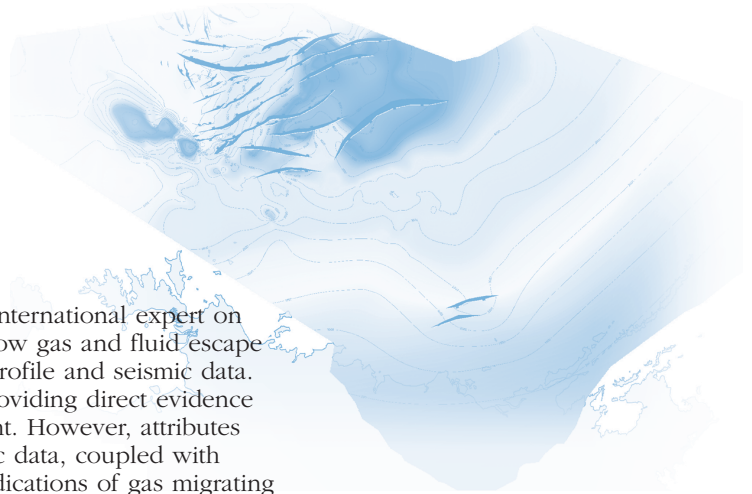

Collaboration with UK consultant Dr Alan Judd, an international expert on shallow gas, is allowing improved interpretation of shallow gas and fluid escape features observed in multibeam, side-scan, sub-bottom profile and seismic data. The integration of sample and survey datasets is now providing direct evidence of microbial gas within the upper few metres of sediment. However, attributes observed in both sub-bottom profiles and deeper seismic data, coupled with remote-sensing and survey data, are providing strong indications of gas migrating throughout the upper 100 metres of sediment, likely sourced from much deeper within the stratigraphic section. This supports interpretations for the existence of an active petroleum system and the existence of hydrocarbons in the northern Arafura Basin.

Results of Geoscience Australia's framework study and seepage survey support the claim that the underexplored frontier region of the northern Arafura Basin has exciting new opportunities for the exploration industry.

References

1. Earl KL. 2006. An audit of wells in the Arafura Basin. Geoscience Australia Record 2006/02.
2. Infoterra Ltd. 2003. Global Seeps—Arafura Sea. Confidential report (unpublished).
3. Logan GA, Ryan GJ, Glenn K, Rollet N, Hemer M, Twyford L & shipboard party. 2006. Shallow gas and benthic habitat mapping, Arafura Sea. RV Southern Surveyor, May–June 2005, post-cruise report, Geoscience Australia Record.
4. Struckmeyer HIM (compiler). 2006a. New datasets for the Arafura Basin. Geoscience Australia Record.
5. Struckmeyer HIM (compiler). 2006b. Petroleum geology of the Arafura Basin. Geoscience Australia Record.

For more information about the Arafura framework study and its products phone Heike Struckmeyer on +61 2 6249 9646 (email heike.struckmeyer@ga.gov.au)

For more information about the Arafura seepage survey phone Graham Logan on +61 2 6249 9460 (email graham.logan@ga.gov.au) ☒

THE BREMER SUB-BASIN

–a new deepwater petroleum opportunity

The recent completion of Geoscience Australia's Bremer Sub-basin Study heralded the first frontier exploration opportunity under the Australian Government's Big New Oil Program.

Barry Bradshaw and Southern Australian Frontiers Project staff

In 2003, the Australian Government announced the injection of an additional \$25 million into Geoscience Australia's petroleum program for new data acquisition and for data preservation and archiving. This boost was followed by the introduction in the 2004 federal budget of tax incentives for exploration in frontier areas.

Geoscience Australia developed a portfolio of potential projects based on integrated programs of seismic acquisition, geological sampling and oil seep detection. Deepwater frontier basins were considered among the most promising candidates and the Bremer Sub-basin was identified as a key frontier area in 2003 (see *AusGeo News* 77). A study commenced in 2004 to determine if it was formed under geological conditions suitable for generating and trapping large volumes of hydrocarbons.

The petroleum potential of this deepwater (100 to 4000 metres) section of the Bight Basin off the southern coast of Western Australia (figure 1) has yet to be tested by exploratory drilling. Previous studies suggested that a series of Middle Jurassic – Early Cretaceous sediment depocentres may contain prospective structures for trapping hydrocarbons (Stagg & Willcox 1991, Bradshaw et al 2003). However, a lack of subsurface geological data, along with the deepwater setting, discouraged exploration for over 30 years.

New datasets

Acquisition of new datasets began in February–March 2004, when Geoscience Australia's Marine Survey 265 collected several hundred subsurface geological samples by dredging a series of submarine canyons that incise up to two kilometres into the sub-basin (figure 1; see Blevin 2005). Samples were analysed to determine age, organic geochemistry and petrographic properties.

A further 1300 kilometres of new seismic data within the sub-basin came from the Southwest Frontiers Survey (S280) of October–November 2004.

Final results of the Bremer Sub-basin Study, incorporating analytical results from dredge sample analyses with seismic interpretations, have recently been released (Bradshaw 2005).

Stratigraphy

The first detailed stratigraphic framework for the sub-basin has been compiled by integrating biostratigraphic and lithofacies data from dredge samples with seismic interpretations. Six seismic stratigraphic units (Bremer 1–6) have been interpreted (figure 2). Most of the basin succession consists of Middle Jurassic – Early Cretaceous sedimentary rocks from the Bremer 1, 2, 3 and 4 units, deposited in ancient rivers and lakes during rifting between Australia and Antarctica. Middle–Late Cretaceous and Cainozoic marine sedimentary rocks are also present, but form only a relatively thin (generally less than one kilometre) stratigraphic section.

Particularly important for petroleum exploration is a series of three major cycles of lacustrine and fluvial sedimentation in the Bremer 2, 3 and 4 units. These cycles provide key petroleum system elements: organic-rich source rocks to generate hydrocarbons, and sandstones overlain by thick mudstones that could reservoir them (figure 2).

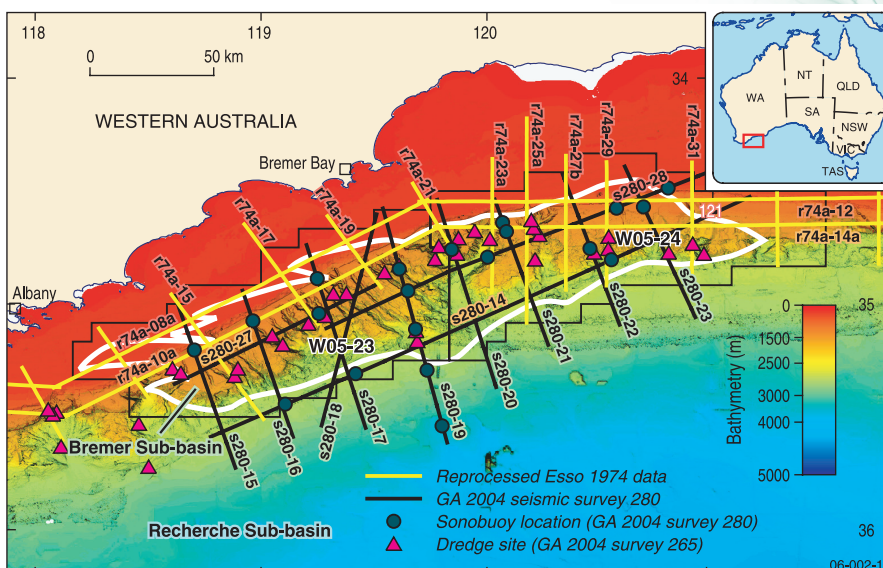

◀ **Figure 1.** Datasets used in Geoscience Australia's Bremer Sub-basin Study superimposed over a bathymetry image. Also shown are 2005 acreage release areas (closing date 20 April 2006) and the sub-basin's extent.

Petroleum systems

One-dimensional burial history modelling (using pseudo-wells located in the main sediment depocentres) indicates that four source rock intervals have the potential to generate and expel hydrocarbons (figure 2). Fluvial-lacustrine mudstones from the Middle-Late Jurassic Bremer 1 unit are generally gas prone, with their main phase of hydrocarbon expulsion modelled to occur during the Tithonian-Berriasian, before most structures formed in the sub-basin. Lacustrine mudstones at the base of the Bremer 2 and Bremer 3 units have good potential to generate oil and gas, with their main phase of hydrocarbon expulsion modelled to occur during the Valanginian-Cenomanian, about the same time that most traps formed.

Coaly source rocks at the top of Bremer 3 unit—in the thickest basin sections from the central sub-basin—had potential to generate and expel hydrocarbons during the Barremian-Cenomanian, following trap formation. Evidence for hydrocarbon generation in the sub-basin includes several dredge samples with trace oil inclusions identified by fluid inclusion analysis, and fluorescing oil observed in the sedimentary matrix during vitrinite reflectance fluorescence analysis.

Structures and traps

The Bremer Sub-basin is characterised by a series of five main sediment depocentres that developed during rifting between Australia and Antarctica in the Middle-Late Jurassic. An extensive area over which hydrocarbons could have been generated is located in the Athena and Zephyr depocentres in the central part of the sub-basin, where sediments are 4 to 9.5 kilometres thick (figure 3). Here, the main exploration targets are fault blocks in water depths from 1000 metres to over 2500 metres. The blocks formed during the Valanginian-Aptian, and have the potential to trap around 250 million barrels of oil in place (figure 4). The main risk for exploring these structures is that many faults reactivated during Late Cretaceous break-up, which could have resulted in leakage of hydrocarbons.

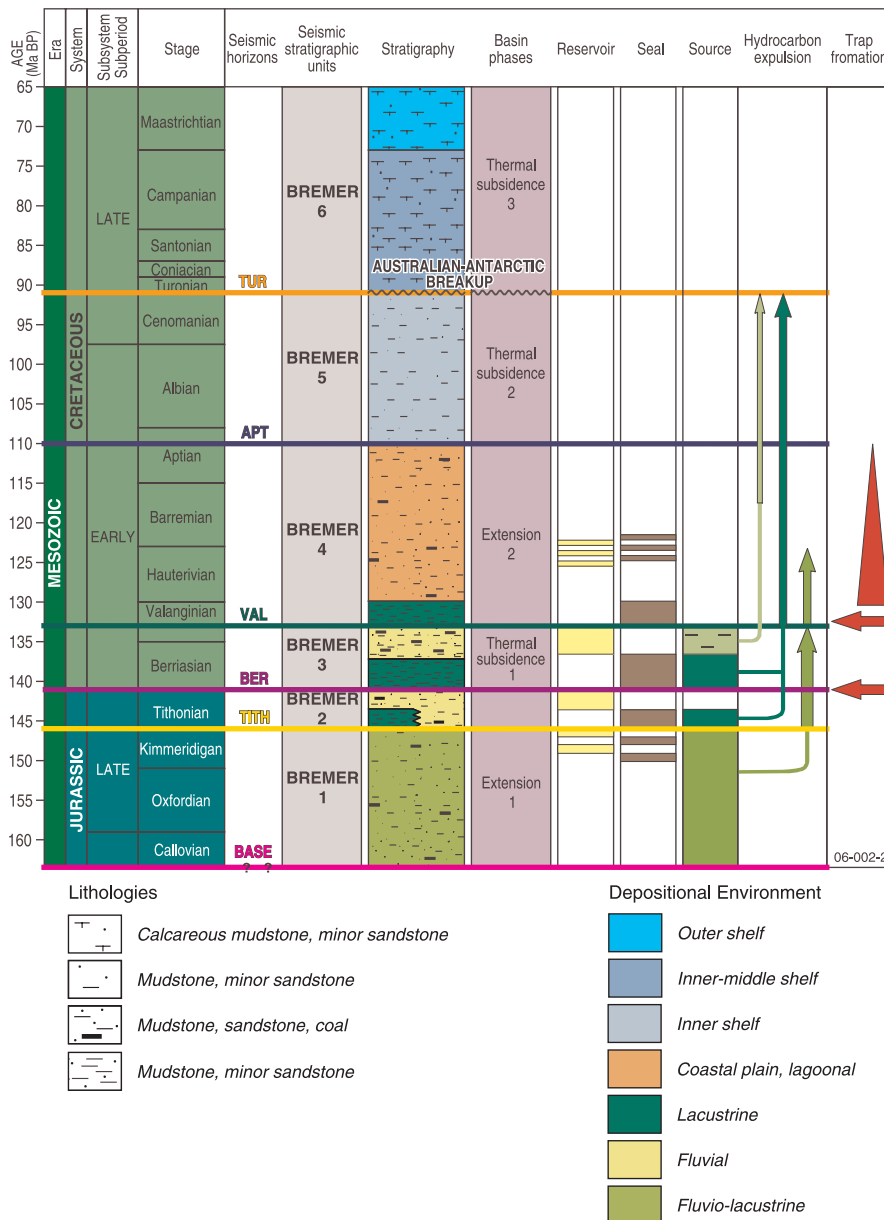
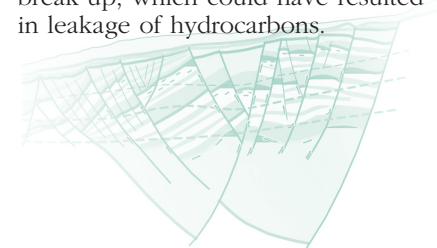

▲ Figure 2. Stratigraphy and petroleum system elements of the Bremer Sub-basin.

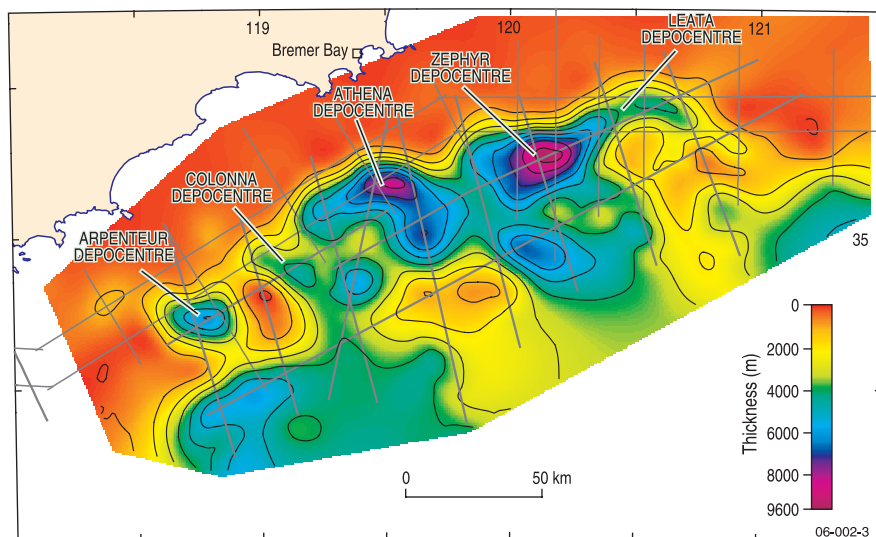

▲ Figure 3. Total sediment thickness map highlighting the main sediment depocentres in the Bremer Sub-basin.

Smaller half graben containing four to five kilometres of sediments occur in the Arpenteur, Colonna and Leata depocentres in the western and eastern parts of the sub-basin (figure 3). The main exploration play in these depocentres is large anticlinal structures that formed during the Valanginian–Aptian and have the potential to trap 500 million barrels of oil in place (figure 5). The main risk for exploring these structures, which are in water depths of 500 to 800 metres, is whether enough hydrocarbons were generated from underlying source rocks after the anticlines had formed.

Acreage release

Historically, the largest hydrocarbon fields have usually been discovered early in the exploration of a petroleum basin. Acreage release blocks in the Bremer Sub-basin provide an opportunity to use these new datasets and interpretations, take advantage of the 150% tax uplift for frontier exploration, and drill the largest prospects in a potential new oil province.

Two designated frontier blocks covering the full extent of the Bremer Sub-basin (W05-23 and W05-24) were included in the Australian Government's 2005 acreage release gazettal (figure 1). These blocks are close to existing onshore infrastructure, including the established port of Albany and a gas pipeline at Esperance. The closing date for submission of work program proposals is 20 April 2006.

The complete seismic coverage of the Bremer Sub-basin is now available from the Geoscience Australia Data Repository at the cost of transfer (phone +61 2 6249 9222, email ausgeodata@ga.gov.au).

References

1. Blevin JE (ed). 2005. Geological framework of the Bremer and Denmark sub-basins, southwest Australia, R/V Southern Surveyor Survey SS03/2004, Geoscience Australia Survey 265, post-survey report and GIS. Geoscience Australia Record 2005/05.
2. Bradshaw BE (compiler). 2005. Geology and petroleum potential of the Bremer Sub-basin, offshore southwestern Australia. Geoscience Australia Record 2005/21.
3. Bradshaw BE, Rollet R, Totterdell JM & Borissova I. 2003. A revised structural framework for frontier basins on the southern and southwestern Australian continental margin. Geoscience Australia Record 2003/03.
4. Stagg HM & Willcox JB. 1991. Structure and hydrocarbon potential of the Bremer Basin, southwest Australia. Bureau of Mineral Resources Journal of Australian Geology and Geophysics 12(4):327–337.

For more information phone Barry Bradshaw on +61 2 6249 9035 (email barry.bradshaw@ga.gov.au)

Related websites/articles

AusGeo News 77 (Big New Oil—a progress report)
AusGeo News 77 (Geoscience Australia's Southwest Frontiers Geophysical Survey)

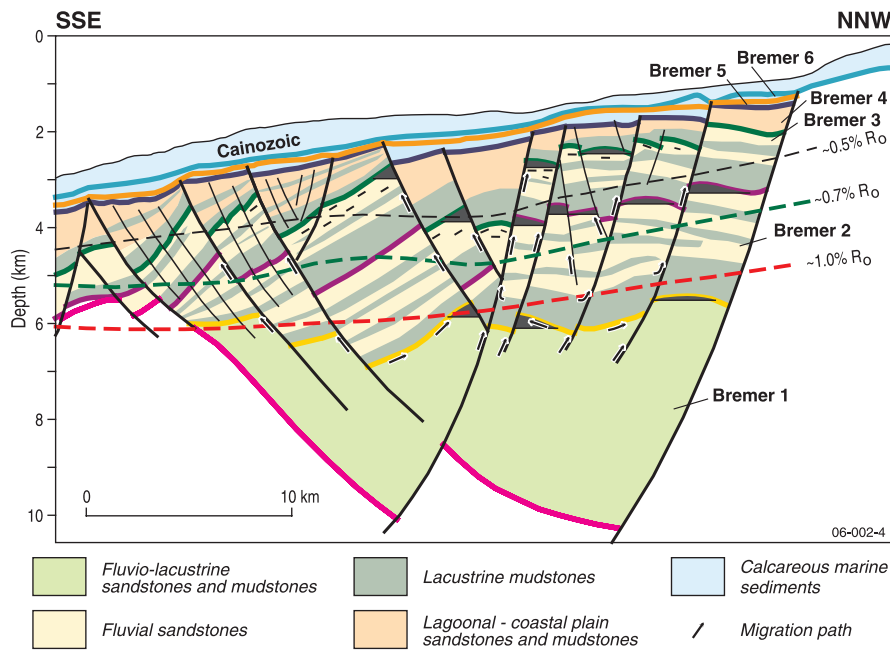

▲ **Figure 4.** Schematic cross-section and play diagram for the Zephyr depocentre, highlighting potential fault block traps.

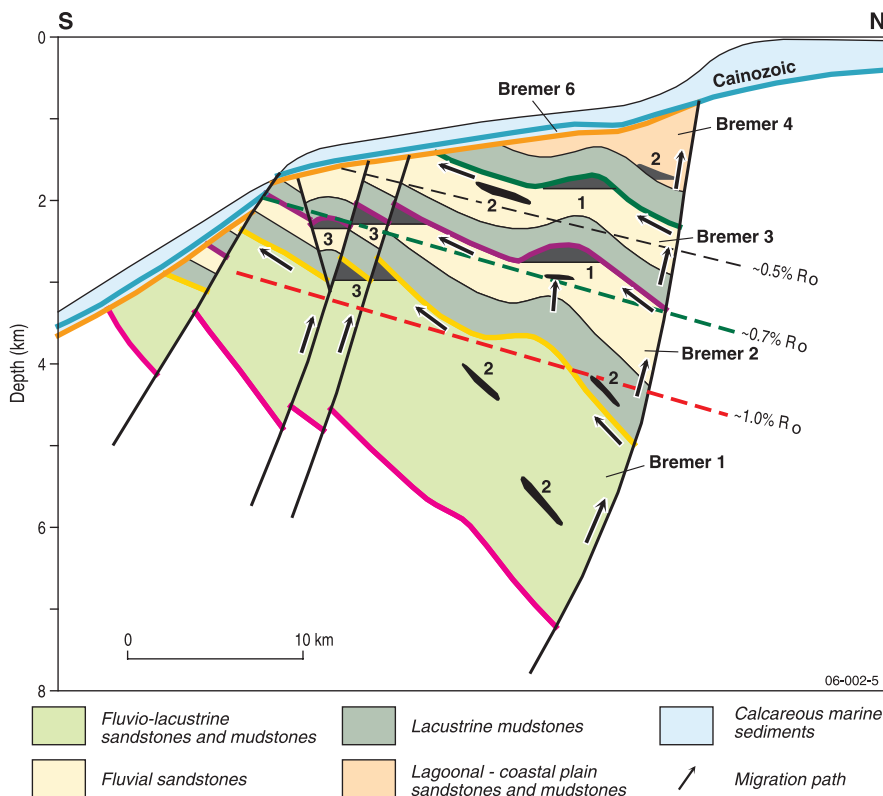

▲ **Figure 5.** Schematic cross-section and play diagram for the Arpenteur and Leata depocentres (1 = anticlinal traps; 2 = combined structural and stratigraphic traps; 3 = fault block traps).

Clean or green – Nitrogen in temperate estuaries

Nitrogen input thresholds for nutrient enrichment identified.

David Heggie

Australia's coastal waterways were formed over the past 7000 years, after sea levels rose during the most recent climate warming phase and flooded the continent's river valleys. Continental weathering, sediment discharges and incessant tide and wave action have subsequently shaped the waterways we now see around the coastline.

Coastal waterways of temperate southern Australia are mainly wave-dominated. High wave energy at the southern coastlines of these systems results in the accumulation of sands from the continental shelf into barriers that restrict the discharge of sediments, water and nutrients into the sea.

Estuarine evolution, sediment and nutrient flushing

Some catchments have experienced low sediment erosion rates since the rise of sea level, while others have experienced high rates. These differences also play an important role in shaping coastal waterways (figure 1).

Immature (unfilled) wave-dominated estuaries are characterised by freshwater and sediment run-off, restricted entrances, poor flushing and small tidal ranges. A comparatively large, low-energy central basin is a characteristic feature of immature estuaries (Heap et al 2004; figures 1 and 2a) where phytoplankton productivity is predominant and intertidal sedimentary environments are very small. Lagoons also have restricted entrances but receive only small fluvial discharges from the catchment. Strand plains are beach ridges and dunes that trap 'ponds' of water, which also have restricted entrances and also receive very little fluvial discharge.

ICOLLS (intermittently closed and open estuaries and lagoons) is a term often used to describe immature wave-dominated estuaries, lagoons and strand plains. The residence time of water in these systems is generally longer than 100 days. Some estuaries remain naturally open, while others have training walls at their entrances that keep them permanently open, resulting in typical water residence times of 20 to 100 days.

River-dominated estuaries (figures 1 and 2b) are characterised by higher fluvial discharges and deeper tidal penetration into the estuary and more abundant intertidal habitats including salt marshes, salt flats, mangroves and melaleucas (Heap et al 2004). High-energy channels allow increased flushing of sediment, water and nutrients into the sea. The residence time of water in these systems is highly variable, typically two to 20 days (or longer) depending on season and location within the tidal reaches.

Nitrogen and eutrophication in temperate estuaries

Eutrophication is the process of nutrient enrichment. It is manifested in excessive plant growth, nuisance and sometimes toxic algal blooms, anoxic events such as fish kills, a green appearance and general loss of amenity value. Wave-dominated systems are moderately to very highly susceptible to eutrophication, principally because poor flushing traps sediments and nutrients from the catchment and naturally low turbidity and high light availability stimulate plant growth (figure 3).

Nitrogen is the most important nutrient limiting plant growth and incipient eutrophication in these systems. Geoscience Australia has conducted many surveys of various wave-dominated estuaries to understand nutrient dynamics and identify the key processes controlling nutrient (particularly nitrogen) balances and incipient eutrophication.

The important processes in this nitrogen balance include the following:

- The principal nitrogen input is run-off from the catchment.
- Internal recycling of nitrogen from underlying estuarine sediments can also be a significant internal source of nitrogen in an estuary.
- Flushing to the sea and denitrification in the sediments (a microbial reaction that converts nitrogen in degrading plants into gas, which is lost to the atmosphere) are the two principal nitrogen outputs.

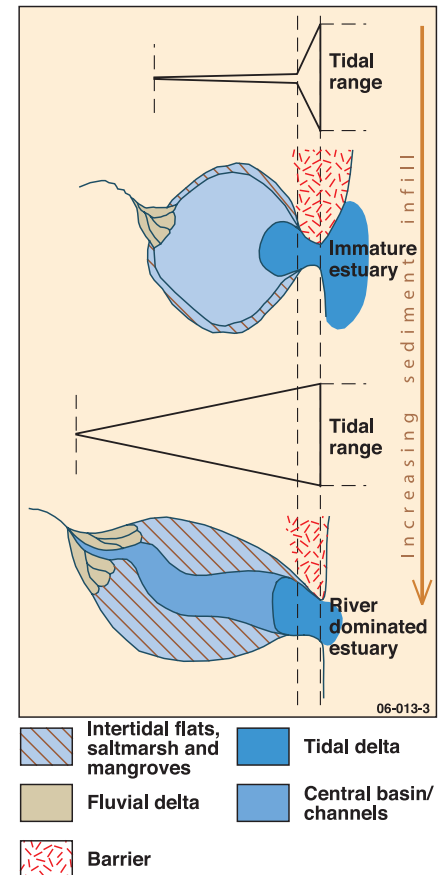

▲ **Figure 1.** Simplified schematic of evolution of wave-dominated systems, showing changing estuarine shapes, sedimentary environments and connectivity with the sea (flushing) with increasing fluvial discharges. (a) Immature estuaries including ICOLLS with low fluvial discharges. (b) River-dominated estuaries with higher fluvial discharges.

- Denitrification efficiency decreases with increasing nitrogen inputs. If denitrification ceases, the internal recycled nitrogen input increases significantly and the potential for eutrophication increases.
- Diatoms—small but dense phytoplankton that rapidly sink into sediments—were found to be an important vector to transport nitrogen to the sediments where denitrification occurs (see 'Diatoms – keeping estuaries clean' in this issue).

Ask ENiD

Geoscience Australia has developed a calculator (Estuarine Nitrogen Dynamics, or ENiD) to estimate the maximum amounts of nitrogen that can be added to estuaries without causing eutrophication, depending on their different morphologies and flushing times.

The results of this exercise (figure 4) show that sustainable nitrogen loads at high denitrification efficiencies are about three to four-fold those at low denitrification efficiencies across all estuarine morphologies at residence times of between about 100 days (ICOLLS) and two days (river-dominated estuaries).

In contrast, the sustainable nitrogen load (at low denitrification efficiencies) increases only about 10% ($45\text{--}50\text{ mg N m}^{-2}\text{ day}^{-1}$) for a five-fold increase in the flushing evident between ICOLLS (residence times >100 days) and permanently open immature estuaries with residence times as short as 20 days. This suggests that construction of breakwaters or training walls to maintain permanent openings and increase flushing is relatively ineffective in controlling eutrophication. The sustainable nitrogen input increases significantly to $155\text{ mg N m}^{-2}\text{ day}^{-1}$ (at low denitrification efficiencies) only when the flushing becomes significant with residence times of, for example, two days in river-dominated estuaries and deltas.

This knowledge of biogeochemical and nutrient enrichment processes suggests that denitrification is a more effective process than flushing to prevent eutrophication. An appreciation by stakeholder groups of estuarine morphologies, flushing characteristics and denitrification are therefore important to enable them to develop sensible strategies to prevent eutrophication. These include limiting the discharge of sediments and nitrogen from catchments and maintaining a healthy and active benthos.

A conservative perspective suggests that nitrogen inputs of less than about $50\text{ mg N m}^{-2}\text{ day}^{-1}$ for most estuaries of temperate Australia will not result in eutrophication and trigger significant ecological changes.

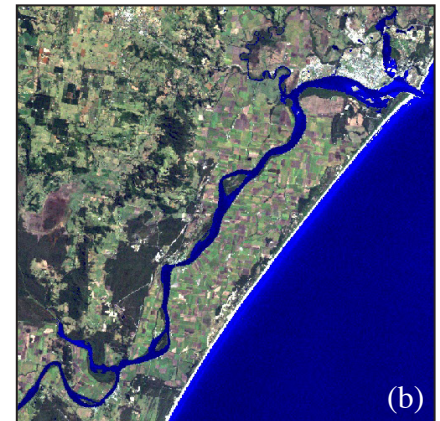
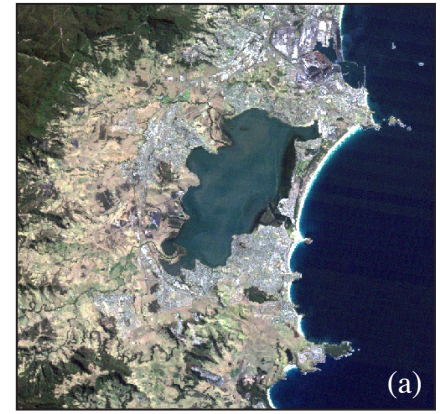

▲ Figure 2. Satellite images of (a) an immature estuary and (b) a river dominated estuary.

◀ Figure 3. Susceptibility of wave-dominated systems to eutrophication.

◀ Figure 4. Sustainable nitrogen loads, sediment denitrification efficiencies and flushing.

Type of Coastal Waterway	Sediment-nutrient Trapping	Natural Turbidity	Flushing (water)	Susceptibility to Eutrophication
Wave-dominated Delta	LOW	LOW	GOOD	MODERATE
Wave-dominated Estuary	HIGH	LOW	POOR	* HIGH VERY HIGH
Strand Plains	LOW	LOW	POOR	MODERATE
Lagoon	MODERATE	LOW	POOR	MODERATE

* Includes coastal lakes

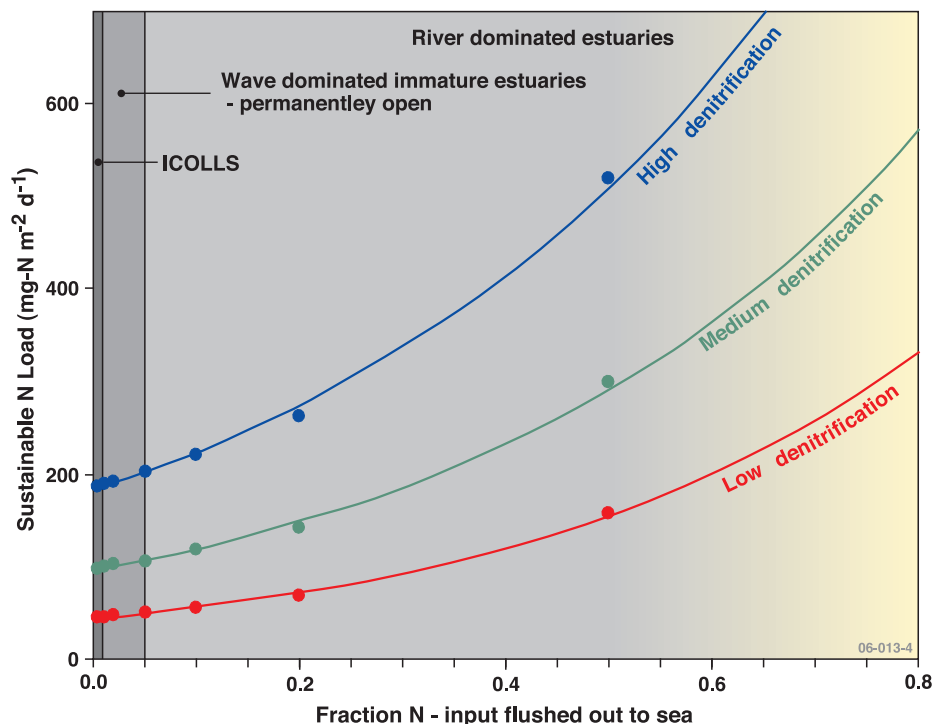

References

1. Heap AD, Bryce S & Ryan D. 2004. Facies evolution of Holocene estuaries and deltas: a large sample statistical study from Australia. *Sedimentary Geology* 168:1–17.

For more information phone David Heggie on +61 2 6249 9589 (email david.heggie@ga.gov.au)

Related websites/articles

Diatoms – keeping estuaries clean
(Ausgeo News 81 article)

DIATOMS – keeping estuaries clean

Diatoms help maintain water quality by moving nitrogen into estuary sediments.

David Heggie

Eutrophication of waterways occurs when the rate of nutrient addition exceeds the rate of removal. Nutrient enrichment can cause prolific plant growth, clogged waterways, nuisance algal blooms, anoxic events, fish kills and a general deterioration in water quality. Nitrogen and phosphorus are the 'culprit' nutrients, but nitrogen is most important in controlling plant growth in temperate estuaries.

Geoscience Australia has conducted several surveys in estuaries in temperate southwest and southeast Australia to identify processes that control eutrophication and maintain 'good' water quality. Because these estuaries are characteristically poorly flushed, they effectively trap sediments and nutrients from their catchments and are particularly prone to eutrophication.

The sediment–water interface

The sediment–water interface in an estuary is a place of intense microbial activity and chemical reactivity. Sediment grains and plant debris—both living and dead—support microbial populations which feed on the organic matter. Animals feed on the microbes and other plant debris, ventilating the sediments as they forage. Oxygen from the overlying waters is moved into sediments around particle grains and used by microbes as they degrade organic matter and release nutrients into water between the grains. Some of these nutrients may migrate into the overlying waters and exacerbate the eutrophication process, but other reactions remove the problematic nitrogen and phosphorus and help to limit or prevent eutrophication.

Geoscience Australia has focused on the sediment–water interface to identify these various reactions and the processes that either release nutrients or remove them from the system.

Phosphorus is very particle-reactive and, once liberated from organic matter, remains trapped in most Australian estuarine sediments. However, after nitrogen is released from organic matter it undergoes a series of microbially mediated reactions (coupled nitrification and denitrification), which may convert some or all of it into nitrogen gas that is lost to the atmosphere.

Denitrification occurs under anoxic conditions (no oxygen), but its precursor (nitrification) occurs under oxic conditions, juxtaposed at the sediment–water interface over millimetre scales.

The efficiency of these nitrification–denitrification reactions is an important control on the eutrophication process. When the denitrification efficiency is high, most nitrogen is lost to the atmosphere and eutrophication may be prevented, but when the denitrification efficiency is low, most nitrogen stays within the estuary and exacerbates eutrophication.

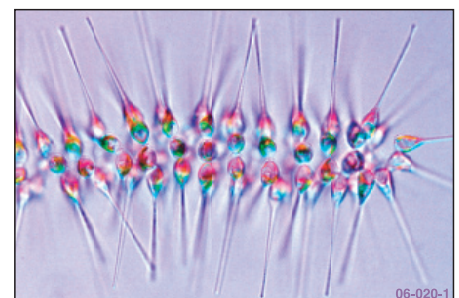

▲ Figure 1. A benthic chamber (Photo D Heggie).

▲ Figure 2. Diatoms are abundant in temperate marine and coastal waters (Images by L Drake & M Doblin).

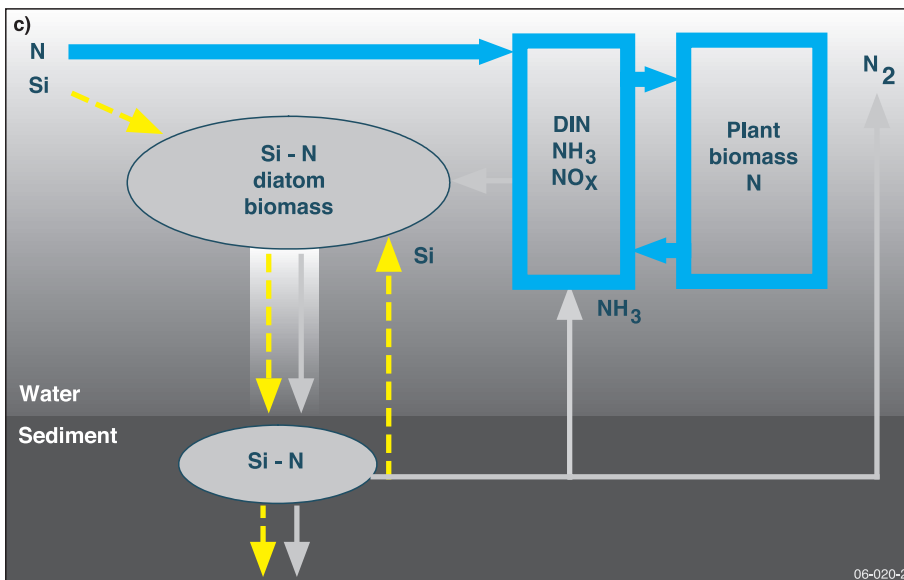
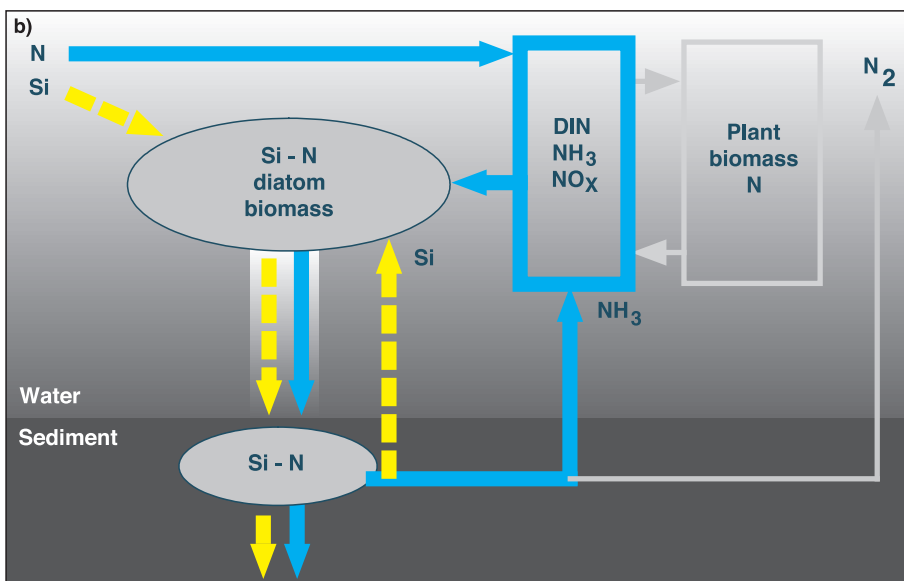
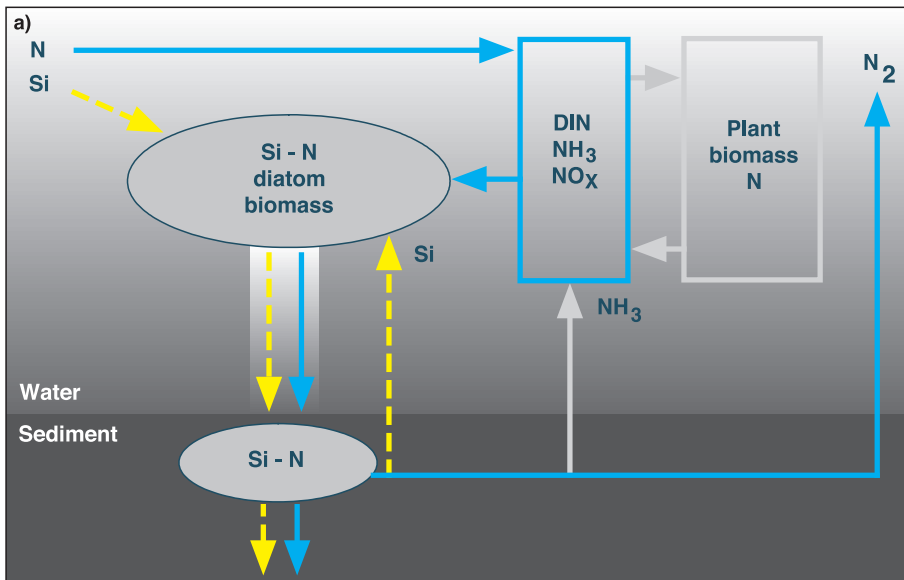

◀ **Figure 3.** Silicate and nitrogen cycles. (a) Denitrification efficiency is high and N₂ is lost to the atmosphere. (b) Denitrification efficiency is low and N is recycled internally to the overlying water as ammonia. (c) Non-diatomaceous biomass is predominant and N is recycled internally in the water column with no denitrification.

Diatoms move nitrogen into sediments

Geoscience Australia has examined these reactions using benthic chambers in several temperate Australian waterways (figure 1). A synthesis of the results from more than 450 chamber deployments found that 86% of the observations could be explained by the degradation of diatomaceous organic matter in the sediments, while the remainder showed mixtures of diatomaceous matter and other unspecified organic plant materials.

Diatoms are generally about 0.1 millimetres in diameter and are predominant in temperate waters (figure 2). They sink relatively heavily, so they sink rapidly to the sediments. Their abundance in temperate Australian waterways is important, because they transport nitrogen into the sediments where coupled nitrification and denitrification leads to nitrogen being lost to the atmosphere.

Three scenarios, each with different pathways of nitrogen-cycling, illustrate how both the absolute and relative abundances of diatomaceous plant biomass produced in an estuary affect denitrification and, ultimately, eutrophication and water quality.

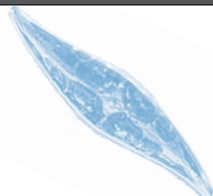

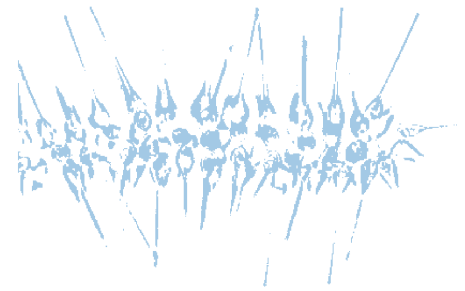

◀ **Figure 4.** Abundant macrophytes and macroalgae in an estuary (Photo D Heggie).

Healthy estuaries and ‘good’ water quality

Reactive nitrogen dissolved in estuarine waters occurs principally in two species—ammonia (NH_3) and oxidised nitrogen (NO_x), which are jointly known as DIN (dissolved inorganic nitrogen, shown in blue in figure 3). Silicon exists as a single-species silicate (yellow). Silicon, nitrogen and phosphorus (not shown) combine (figure 3a) during the photosynthetic process to form diatoms, which sink to the sediments, degrade and liberate silicate back into the overlying waters to participate in further rounds of plant growth.

Nitrogen is released to the water in the sediment as ammonia and oxidised (nitrification) to produce nitrate and nitrite, which are subsequently reduced during denitrification to produce nitrogen gas (in figure 3a, the bold blue line illustrates this pathway). Low loads of nitrogen and abundant silicate favour diatom biomass, which sinks to the sediment and, when combined with an active benthos ventilating the sediments with oxygen, promotes efficient nitrification and denitrification and eventual nitrogen removal. Diatom production and sinking are mechanisms to remove nitrogen from estuaries via efficient denitrification, helping to alleviate eutrophication and maintain ‘good’ water quality.

Eutrophic estuaries and ‘poor’ water quality

Two scenarios result in eutrophic conditions and ‘poor’ water quality. The bold nitrogen pathways highlighted in blue (figure 3b) involve diatom production, but in this scenario the rate of diatom biomass production is high, driven by comparatively higher inputs of nitrogen than in the first scenario. The cycling of silicate (yellow) is the same, but the cycling of nitrogen is significantly different.

Diatoms transport nitrogen to the sediments, but high loads of nitrogen cause the nitrification and denitrification reactions to be inefficient. Nitrogen is then released into overlying waters principally as ammonia, which fuels further plant growth. Nitrogen is recycled internally in this pathway rather than being removed from the estuary, exacerbating eutrophication and probably eventually resulting in significant ecological changes, such as an abundance of macroalgae, macrophytes (figure 4) and/or nuisance phytoplankton and bacteria.

The third scenario (figure 3c) involves preferential assimilation of nitrogen into nonsiliceous phytoplankton, macroalgae and macrophytes. Silicate is limiting in this scenario because of comparative nitrogen enrichment, and diatom production is not favoured during photosynthesis. Nonsiliceous phytoplankton do not contain a silicate frustule (siliceous cell wall) and do not rapidly or always sink, so they do not transport nitrogen effectively to sites of nitrification and denitrification in the interfacial sediments. Instead, nutrients are released directly from the plants into the water column overnight, as part of the respiration cycle.

These plants therefore act simply as ‘sponges’, soaking up nutrients from various sources during daylight and releasing them into the water column at night. In this way, little nitrogen from the catchment gets to the sediments where it can be denitrified. This pathway (shown in bold) is also one through which nitrogen is recycled internally; it results in the retention of nitrogen in estuaries, exacerbating eutrophication and possibly leading to further shifts in local ecology.

**For more information phone
David Heggie on +61 2 6249 9589
(email david.heggie@ga.gov.au)** 📧

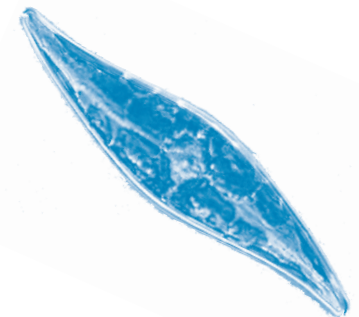

A TIME MACHINE for Geoscience Australia

A new SHRIMP ion microprobe means improved geochronological support for mineral exploration in Australia.

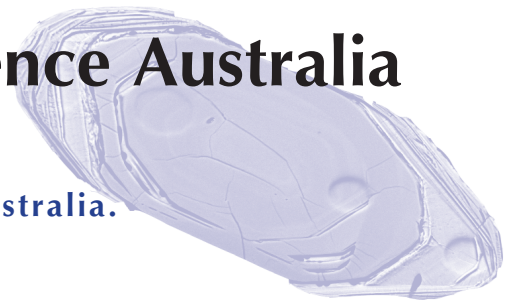

Richard Stern

'Let's SHRIMP those zircons!' That kind of talk will become more common in Geoscience Australia when a new sensitive high resolution ion microprobe (SHRIMP) is installed in the basement of the Canberra headquarters next year. 'SHRIMP' has become part of the lexicon of geoscience, and now of Geoscience Australia.

Australian Scientific Instruments of the ACT was contracted in November 2005 to build and supply the specialised SHRIMP II. The signing of the contract by Dr Neil Williams, Geoscience Australia's CEO, and Ted Stapinski, ASI's Director (figure 1) was the culmination of a year-long effort by Geoscience Australia staff. In a novel partnership between government and industry, instrument time will be licensed back to ASI to conduct customer demonstrations and trial new hardware and software developments.

Smarter prospecting

It's getting harder to find new world-class mineral deposits in Australia, and mineral explorers need a comprehensive understanding of mineral systems within current and prospective terranes. One of Geoscience Australia's main roles is to provide key national-scale datasets, including geochronology, as a framework for exploration investment, particularly in greenfield regions and under cover. For example, Geoscience Australia and partners recently used SHRIMP geochronology to develop the geological event framework for the western Mount Isa Inlier (Neumann et al 2005). Geochronology, especially U-Pb (decay of uranium to lead) and targeted Ar-Ar (decay of potassium to argon) geochronology, provides the crucial time dimension of geological processes that form mineral deposits.



▲ **Figure 1.** Signing the SHRIMP purchase contract at Geoscience Australia. Seated are Ted Stapinski (Director, ASI) and Neil Williams (CEO, Geoscience Australia). At back (left to right) are Peter Southgate and Richard Stern (Geoscience Australia) and Ed Roberts (General Manager, ASI).

The purchase of a SHRIMP underlines the critical importance of geochronology in supporting mineral exploration investment in Australia. Geoscience Australia currently obtains all of its U-Pb geochronology data through SHRIMP instruments located in external labs, with Geoscience Australia staff visiting those facilities to make measurements. The in-house facility (figure 2) will enable better control over quality, quantity and timeliness of age data delivered to Geoscience Australia and its partners in the state and territory geological surveys. The new SHRIMP will revitalise the organisation's geochronology laboratory, enabling it to achieve world's best standards for Geoscience Australia and its clients. Geoscience Australia joins the Geological Survey of Canada, the United States Geological Survey, the Chinese Academy of Geological Sciences, the All Russian Geological Research Institute, and other major national research agencies throughout the world in recognising the importance of SHRIMP geochronology as a key resource in supporting mineral exploration.

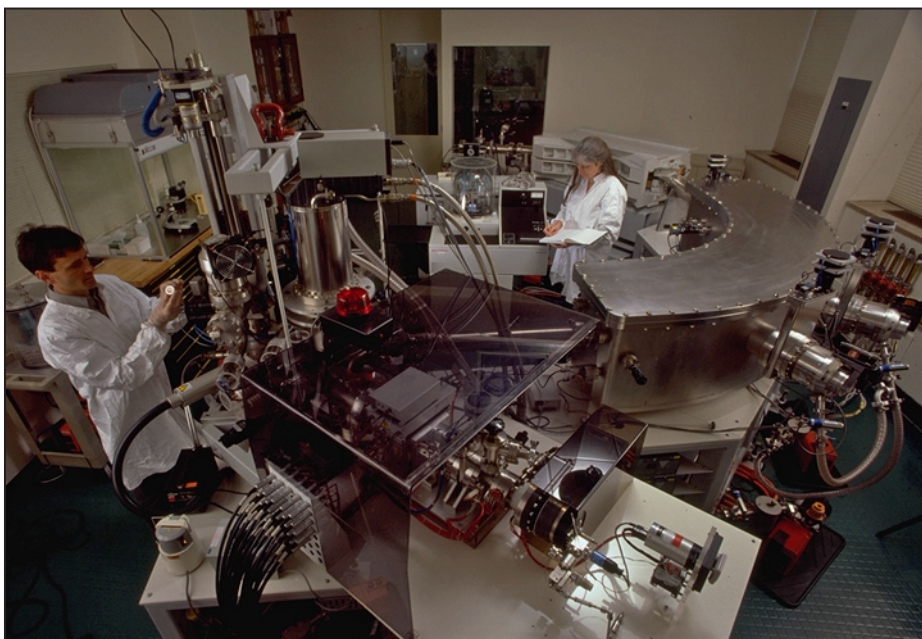

▲ **Figure 2.** A SHRIMP ion microprobe laboratory.

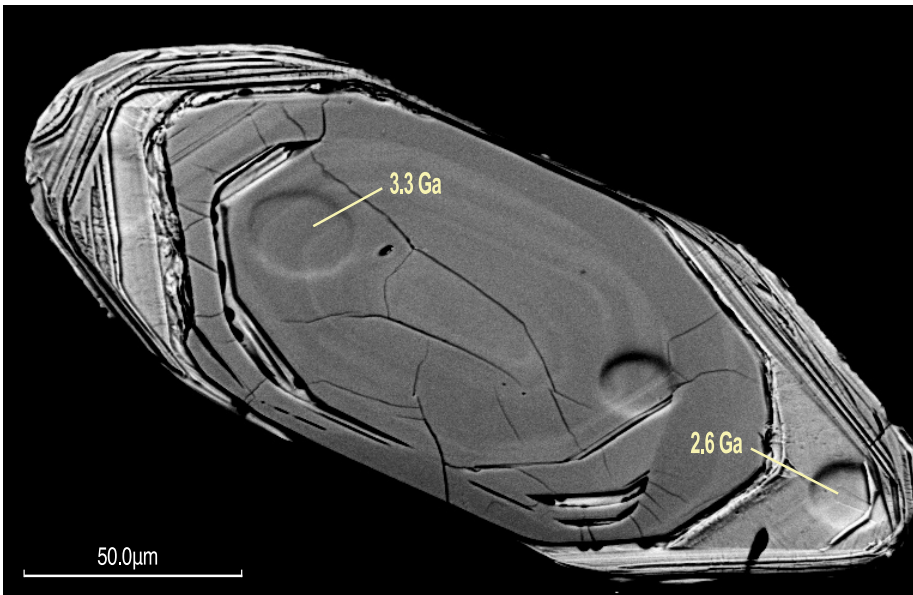

◀ **Figure 3.** A sectioned zircon grain from a metamorphosed greywacke, imaged with backscattered electrons, subsequent to SHRIMP analysis (craters visible). A 3.3 Ga detrital core (dark grey) is mantled by a 2.6 Ga metamorphic overgrowth. From Böhm et al (2003).

Aussie excellence

The SHRIMP is an internationally-recognized geochronology technology that was developed at the Australian National University in the late 1970's (Clement et al 1977). The prototype SHRIMP I became functional in 1980, and was followed in 1992 by a significantly improved version, SHRIMP II. Ion microprobes utilize a beam of charged particles to probe solids, such as individual mineral grains, for the purpose of elemental and isotopic analysis, and although these instruments were already used for geochemical purposes, none was tailored for geochronology until the introduction of the SHRIMP.

Commercial distribution of the SHRIMP II by ASI began in 1993 with the delivery of an instrument to Curtin University of Technology, and since then ASI has sold the SHRIMP II and an experimental design, SHRIMP-RG, to several research institutions around the world. The GA-SHRIMP II, expected to be delivered in the third quarter of 2007, will be the 14th instrument (Table 1). An international community of scientists that primarily use the SHRIMP and competitor technologies has emerged to become a major force in U–Pb geochronological research.

Using the time machine

U–Pb geochronology of accessory minerals is the dominant means of obtaining absolute and precise ages for ancient geological events recorded in rocks within the continental crust, the host of Earth's valuable mineral resources. Minerals such as zircon ($ZrSiO_4$), monazite ($CePO_4$), and titanite ($CaTiSiO_5$) incorporate trace quantities of uranium during crystallisation. The two isotopes of uranium (^{238}U , ^{235}U) radioactively decay to form two isotopes of lead (^{206}Pb , ^{207}Pb , respectively), along with several intermediate daughter elements. The isotopic ratios of lead to uranium, and the two lead isotopes, can be used to calculate the radiometric ages of the minerals. The half-lives of the uranium isotopes are known to high precision, and are long enough to permit dating of geological events that occurred a few million to billions of years ago.

Table 1. SHRIMP ion microprobes around the world

Instrument number	Institution	Location	SHRIMP model	Year of commissioning
1	Australian National University	Canberra	I	1980
2	Australian National University	Canberra	II	1992
3	Curtin University of Technology	Perth	II	1993
4	Geological Survey of Canada	Ottawa	II	1995
5	Hiroshima University	Hiroshima	II	1996
6	Australian National University	Canberra	RG	1998
7	Stanford University	Stanford	RG	1998
8	National Institute of Polar Research	Tokyo	II	1999
9	Chinese Academy of Geological Sciences	Beijing	II	2001
10	All Russian Geological Research Institute	St. Petersburg	II	2003
11	Curtin University of Technology	Perth	II	2003
12	University of São Paulo	São Paulo	II	(2006)
13	Chinese Academy of Geological Sciences	Beijing	II	(2007)
14	Geoscience Australia	Canberra	II	(2007)

() projected



The success of U–Pb geochronology lies partly in its wide applicability. Robust ‘mineral chronometers’ like zircon are found in almost all crustal rocks and can reveal the timing of magmatism, metamorphism, mineralisation and sedimentation. Other factors include the potential for very high analytical precision (for example, 0.1–1.0%), and the ability to determine whether the U to Pb radiometric clocks have remained undisturbed by comparing ages from the two decay series. There are several other useful and complementary methods of radiometric dating, such as the Ar–Ar method also used by Geoscience Australia, but none with the widespread utility of U–Pb geochronology.

Conventional U–Pb geochronology by thermal ionisation (TIMS) is carried out on whole grains or parts of whole grains, requires careful chemical treatment to isolate the uranium and lead, and normally takes several days to generate age data. SHRIMP geochronology doesn’t require chemical isolation of the uranium and lead in samples, so U–Pb ages can be obtained directly from the mineral chronometers at a spatial resolution of 5–30 µm without the need for a chemistry laboratory. Ages of individual growth zones within single crystals (figure 3) can be measured very rapidly, in about 15 minutes. And ages of minerals can be obtained in situ, allowing direct dating of minerals in thin sections. Applications of in situ geochronology are likely to have major impacts in many fields over the next decade.

A date for all

When SHRIMP U–Pb dating was introduced, it was viewed sceptically by a geochronological community accustomed to the rigours of TIMS, which produces results of unsurpassed precision and accuracy. Individual SHRIMP spot ages are significantly less precise, due to the much smaller amounts of mineral analysed (a few nanograms of sample per spot). Nevertheless, the 1983 discovery of the oldest (detrital) zircons on Earth (Froude et al 1983) focused attention on the value of SHRIMP technology and boosted its credibility as a viable technique.

Many subsequent SHRIMP studies have demonstrated that it’s often valid to compromise precision if more ages can be acquired or the internal age complexities of a mineral can be understood (Williams 1998). SHRIMP addresses the two main weaknesses of TIMS—low data throughput and mixing of ages due to the relatively large samples analysed. Nevertheless, the TIMS method remains a powerful and relevant technique and is unlikely to be replaced by emergent technologies for certain critical applications (Parrish & Noble 2003).

Over the past two decades, SHRIMP geochronology has evolved and moved from the fringe to the mainstream. One of its biggest impacts is the enormous increase in the volume and scope of U–Pb geochronology, particularly in Australia but now increasingly on other continents. Our knowledge of the ages of ancient magmatism, tectonism, sedimentation and mineralisation would be significantly poorer if not for the advent of SHRIMP technology, which essentially allowed U–Pb geochronology to expand beyond a few highly skilled geochemists and into the hands (literally, by a click of the mouse) of many geologists interested in the ages of rocks.

References

1. Böhm CO, Heaman LM, Stern RA, Corkery MT & Creaser RA. 2003. Nature of Assean Lake ancient crust, Manitoba: a combined SHRIMP-ID-TIMS U–Pb geochronology and Sm–Nd isotope study. *Precambrian Research* 126:55–94.
2. Compston W, Clemens SWJ, & Newstead G. 1977. Design of a large, high resolution ion microprobe. *Proceedings of the First International Conference on SIMS* (abstract).
3. Froude DO, Ireland TR, Kinny PD, Williams IS, Compston W, Williams IR & Meyers JS. 1983. Ion microprobe identification of 4,100–4,200 Myr-old terrestrial zircons. *Nature* 304:616–618.
4. Neumann N, Southgate P, McIntyre A & Gibson G. 2005. New data on rock ages from Mt Isa Inlier. *AusGeo News* 78, 6–7.
5. Parrish RR & Noble SR. 2003. Zircon U–Th–Pb geochronology by isotope dilution-thermal ionization mass spectrometry (ID-TIMS). In: Hanchar JM & Hoskin PWO (eds), *Zircon, Reviews in Mineralogy and Geochemistry* 53, Mineralogical Society of America, 183–213.
6. Williams IS. 1998. U–Th–Pb geochronology by ion microprobe. In: McKibben MA, Shanks WCP & Ridley WI (eds), *Applications of Microanalytical Techniques to Understanding Mineralizing Processes, Reviews in Economic Geology* 7, Society of Economic Geologists, 1–35.

For more information on the Geoscience Australia SHRIMP and geochronology program, phone Richard Stern on +61 2 6249 9377 (email richard.stern@ga.gov.au)

Related website/articles

Ausgeo News 78
(new data on rock ages from Mt Isa Inlier)

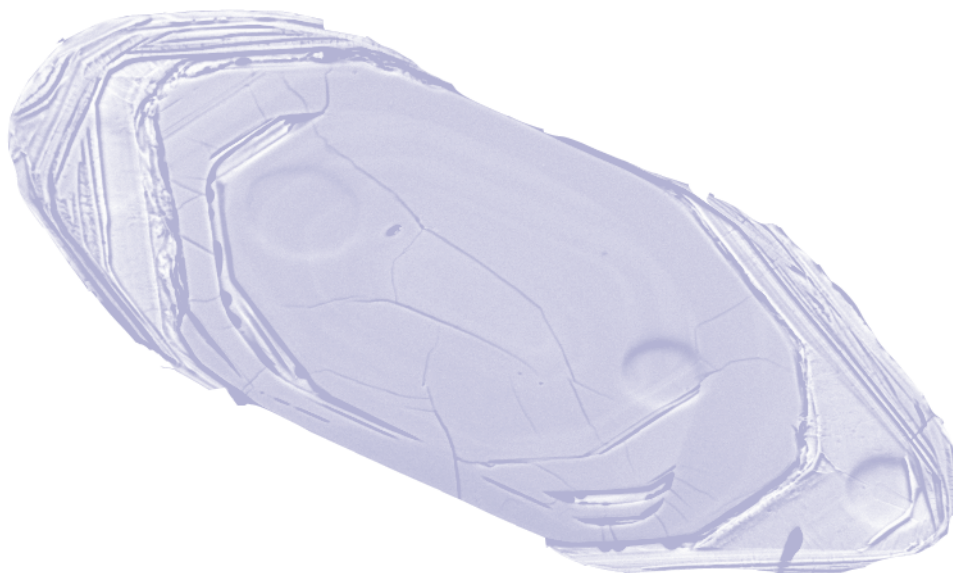

Beating the **BIG BLOWS**

New research assesses severe-wind risks.

Bob Cechet, Adrian Hitchman and Mark Edwards

On Christmas Day 1974, Cyclone Tracy devastated Darwin with winds gusting to 237 km/h. Tracy killed 65 people and caused damage of over A\$837 million (1999 dollars), according to the Insurance Disaster Response Organisation.

Although tropical cyclones rarely assault Australian cities, severe winds cause significant damage each year. While cyclonic winds are a northern Australian phenomenon, winds driven by thunderstorms and tornadoes also inflict serious damage and sometimes cause loss of life in southern states. Data from insurance companies indicate that severe winds account for around 40% of damage to Australian residential buildings (Blong 2005)—significantly more than other natural hazards, such as floods (22%), bushfires (19%), and earthquakes (6%).

New research by Geoscience Australia's Risk Research Group aims to reduce the loss of life and the property damage from such severe-wind events in Australia.

Cyclones

Most Australian cyclones develop in the Indian Ocean off the northwest coast of Western Australia, off the northeast coast of Queensland in the Coral Sea and, to a lesser extent, in the Arafura Sea northwest of the Northern Territory.

Western Australia's northwest coast has endured the strongest Australian cyclones, but the region is so sparsely populated that cyclones which would cause massive destruction in more densely settled areas often cross the coast with little impact on communities. The Pilbara, Western Australia's critical northwest resources region, escaped major damage from the passage of Cyclone Clare in January 2006, but the key industrial centres of Karratha and Dampier were hit by winds of up to 195 km/h as the Category 3 cyclone struck the coastal region.

Queensland has seen relatively few tropical cyclones in recent decades compared to the long-term average. The last to cause considerable damage in the state was Cyclone Aivu, which crossed the coast near the towns of Ayr and Home Hill in April 1989. Aivu's winds gusted close to 200 km/h and caused over \$70 million damage, mainly to sugarcane crops.

Thunderstorms

Severe thunderstorms, which are more common than other natural hazards, usually affect smaller areas than tropical cyclones. They can occur anywhere in Australia but are most significant in northeast New South Wales and southeast Queensland. Although severe thunderstorms can occur at any time of the year, they are rare during the dry winter months in the north, and most strike between September and March because of the high solar energy loads in spring and summer. Severe winter storms linked to cold fronts are common in the southwest of Western Australia and southern Australia.

In mature thunderstorms, falling rain and hail drag the surrounding air downwards. Evaporation from raindrops cools nearby air, accelerating the downward rush. This strong downdraught, often referred to as a 'thunderstorm downburst' or 'micro-burst', spreads out (mainly in the direction of storm movement) when it reaches the ground, producing cool, gusty wind that can cause serious damage. Each year, on average, severe storms (thunderstorms and tornadoes) are responsible for about one quarter of the annual damage attributable to wind events (Blong 2005). Records of storm impact show that the most damaging storms have occurred in the populous southeast quarter of the continent.

Tornadoes



▲ **Figure 1.** Housing estate destroyed by Cyclone Tracy in 1974 (Bureau of Meteorology).

Tornadoes are the rarest and most violent storms. Thought to be formed by interaction between strong updraughts and downdraughts of air in severe thunderstorm clouds, they are rapidly rotating columns of air that descend in the well-known funnel shape (vortex) from the base of the storm cloud. A tornado vortex, which can range in width from a few metres to hundreds of metres, contains very damaging winds that can reach more than 450 km/h. Tornado damage is normally restricted to small areas but is very intense.

On 2 February 1918, the weather in Melbourne was humid and unsettled. A slow-moving low-pressure trough crossed Victoria and late afternoon thunderstorms developed over the city. About 4.50 pm, the so-called 'Brighton cyclone' struck the bayside suburb. The 'cyclone', which was apparently two separate tornadoes, followed about five minutes later by a third, caused significant damage. Wind speeds were estimated at 320 km/h, making this possibly the most intense tornado to hit a major Australian city (BoM 2006b). Many buildings were totally destroyed, and even well-constructed houses were severely damaged. At one location, two tornado tracks crossed, creating (in the language of the day) a 'veritable orgy of destruction' (BoM 2006b).



◀ **Figure 2.** Housing damaged by a tornado in Bendigo, Victoria, in May 2003 (Geoscience Australia).



The Bureau of Meteorology's severe storms database records over 360 tornadoes across NSW since 1795, with most occurring in late spring and summer (BoM 2006a). However, many more tornadoes are likely to have twisted, unnoticed, across sparsely populated or unpopulated regions.

Tornadoes occur more often in Australia than most people suspect, but they are neither as prevalent nor as intense as those in 'tornado alley' in the great plains of the central United States. There the relatively flat land allows cold, dry, polar air from Canada to meet warm, moist, tropical air from the Gulf of Mexico, making the plains the world's best breeding ground for storms that produce tornadoes.

Defining the risk

Geoscience Australia's Risk Research Group is collaborating with the Bureau of Meteorology and CSIRO to analyse the historical and geological record of all severe-wind events in Australia, as well as in the numerical modelling of the spatial hazard associated with significant events. This work is undertaken in relation to the Disaster Mitigation Australia Package (DMAP) coordinated by the Department of Transport and Regional Services (DOTARS). Geoscience Australia is funded by DOTARS to facilitate national, systematic and rigorous risk assessments for sudden-impact national hazards as a part of DMAP.

The Bureau of Meteorology has valuable information describing the patterns and regularity of severe winds experienced by Australian capital cities, major country towns and other sites over the past 100 years. However, severe winds from small-scale events such as thunderstorms and tornadoes have not always been captured in the observed record. Additional information in the geological record, properly interpreted, can extend our understanding of wind patterns and regional-scale extreme events back many thousands of years. Using statistical analysis, sophisticated computer models and our understanding of climate change, it will be possible to estimate the likelihood of severe winds occurring in every part of the continent during the 21st century and beyond.

This information will be used by Risk Research Group engineers to estimate the damage such winds are likely to cause to commercial and residential buildings and the impact on critical infrastructure. Consequently, likely patterns of damage and financial losses can be estimated for regions, cities and towns across the nation. These informed estimates can be used by Geoscience Australia economists to assess longer term direct and indirect economic impacts of severe-wind events, and by our social scientists to develop strategies to support communities recovering from them.

This will build preparedness, help to mitigate future impacts, make communities more resilient, and enable swifter disaster recovery:

- Emergency managers will be able to improve response planning by utilising the predicted consequences and assessed likelihoods of scenario events.
- Capability gaps can then be more clearly identified and plans developed to improve the effectiveness of post-event emergency and recovery operations.
- Planners and engineers will be able to identify more accurately factors contributing to the risk of damage to infrastructure and develop strategies to improve resilience through measures such as improved building codes and community awareness.
- Insurance companies will be better able to estimate their portfolio risk and thus develop the most appropriate insurance premium schedules and incentives for property holders in high-risk areas and the broader community.

- Community members will be better informed about their relative level of risk and thus be more likely to take up appropriate insurance cover.

Planning for this research took a significant step forward in December 2005, when engineers and severe-weather meteorologists from Australia and New Zealand gathered in Canberra to review and refine Geoscience Australia's proposed wind risk assessment strategies. Chaired by Dr John Holmes, chairperson of the Australia – New Zealand Structural Wind Loading Standards Committee, this workshop assisted the Risk Research Group to consider methodologies for investigating the temporal and spatial distribution of severe-wind risk within Australia.

The research will allow us to better understand cyclone, thunderstorm, tornado and winter storm hazards, anticipate their impacts and, with appropriate planning, mitigate or reduce their effects.

References

1. Blong R. 2005. Natural hazards risk assessment: an Australian perspective. Issues in Risk Science series. Benfield Hazard Research Centre, London.
2. BoM. 2006a. Bureau of Meteorology, Canberra <www.bom.gov.au/weather/nsw/sevwx/tornadofact.shtml>
3. BoM. 2006b. Bureau of Meteorology, Canberra <www.bom.gov.au/climate/c20thc/storm1.shtml>

For more information phone Bob Cechet on +61 2 6249 9246 (email bob.cechet@ga.gov.au)

Related websites

Insurance Disaster Response Organisation:
www.idro.com.au

In Brief

SMART EXPLORATION gets Geoscience Australia support

In July 2005, the Queensland Department of Natural Resources and Mines announced a \$20 million Smart Exploration initiative to stimulate mineral exploration in the state over the next four years.

The first two years of the program involve acquisition of airborne geophysical and ground gravity data in areas with the highest potential for discovery of mineral resources. Geoscience Australia is managing the geophysical data acquisition in the Mount Isa region and the Bowen and Surat basins in central and southern Queensland.

The basins are major energy provinces, with large reserves of coal and coal seam gas. While most large coal deposits have been identified, opportunities remain for further discoveries of economic deposits.

The Mount Isa region has delivered several world-renowned mineral deposits over the past century, but further potential exists. The region is highly prospective for base and precious metal deposits of the Mount Isa style (sedimentary-hosted silver–lead–zinc) and Broken Hill style (high-grade metamorphic silver–lead–zinc), breccia-hosted copper deposits, and iron–copper–gold deposits beneath shallow cover.

Geoscience Australia is managing the geophysical data acquisition for the entire program, and awarded five contracts for geophysical data acquisition in November 2005 (see table 1). When completed, these surveys will release more than 11 900 new gravity stations and over 387 000 line kilometres.

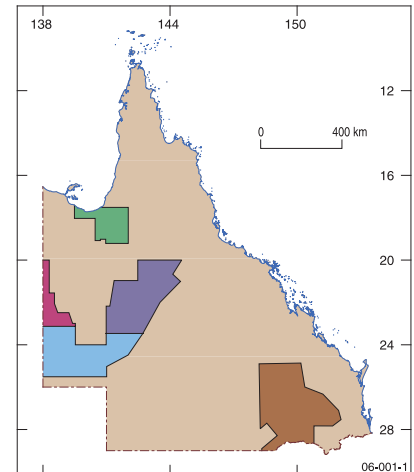

Queensland Smart Exploration Initiative

AIRBORNE GEOPHYSICAL SURVEYS

- Croydon, 400m E-W, 80m agl, ~35310 sq km
- East Mount Isa, 400m E-W, 80m agl, ~91510 sq km
- West Mount Isa, 400m E-W, 80m agl, ~22030 sq km
- South West Mount Isa, 400m E-W, 80m agl, ~86190 sq km
- Bowen - Surat, 400m E-W, 80m agl, ~114400 sq km

▲ Figure 1. Airborne geophysical surveys, Smart Exploration initiative.

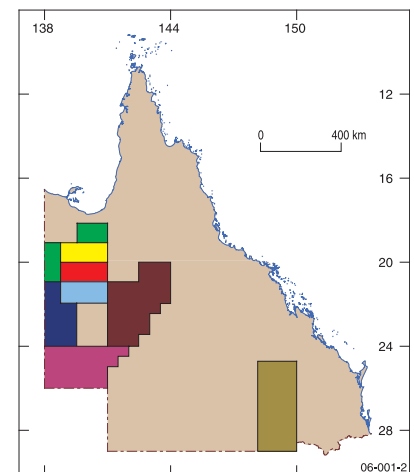

Queensland Smart Exploration Initiative

GRAVITY SURVEYS

- Mount Isa Area A, 2 km spacing, ~26060 sq km
- Mount Isa Area B, 2 km spacing, ~26230 sq km
- Mount Isa Area B, 4 km spacing, ~35020 sq km
- Mount Isa Area C, 2 km spacing, ~25890 sq km
- Mount Isa Area C, 4 km spacing, ~42790 sq km
- Mount Isa Area D, 4 km spacing, ~75460 sq km
- Mount Isa Area E, 4 km spacing, ~97420 sq km
- Bowen - Surat, 4 km spacing, ~85760 sq km

► Figure 2. Gravity surveys, Smart Exploration initiative.

Table 1. Geophysical data acquisition contracts awarded to date

Survey name	Contractor	Area (km ²)	Station/line spacing	Stations/line km	Start date
Bowen–Surat Gravity	Daishsat	85 000	4 km	5 263	Nov 2005
Mt Isa Area A Gravity	Daishsat	26 000	2 km	6 719	March 2006
Bowen–Surat North Magnetic and radiometric	UTS	60 310	400 m	169 882 km	Feb 2006
Bowen–Surat South Magnetic and radiometric	Fugro	54 930	400 m	153 846 km	Feb 2006
Mount Isa West Magnetic and radiometric	Fugro	22 000	400 m	63 533 km	Feb 2006

The completed program will deliver five airborne magnetic and radiometric surveys and six ground gravity surveys (see figures 1 and 2). These surveys will release magnetic and radiometric data from a total of more than 1 200 000 line kilometres and 39 000 gravity stations into the public domain.

The new Bowen–Surat airborne data will be acquired on east–west flight lines spaced 400 metres apart. The Mount Isa West data will be acquired on north–south (north of -21.560813°) and east–west (south of -21.560813°) flight lines 400 metres apart. Ground clearance for both datasets will be 80 metres.

The three remaining airborne surveys will be on east–west lines 400 metres apart, again with a ground clearance of 80 metres. The four remaining gravity surveys will be at station spacings of 2 x 2 kilometres and 4 x 4 kilometres.

For more information phone Murray Richardson on +61 2 6249 9229 (email murray.richardson@ga.gov.au) or David Searle on +61 7 3362 9357 (email David.Searle@nrm.qld.gov.au)

Related websites

Smart Exploration initiative:
www.nrm.qld.gov.au/science/geoscience/smartex.html

Geoscience Australia's impact modelling PROTECTING AUSTRALIA

In November 2005, the Australian Emergency Management Committee (AEMC) approved the formation of a working group to address issues relating to tsunami risk in Australia, and the implementation of the emergency management elements of the Australian Tsunami Warning System. The AEMC is Australia's peak consultative emergency management forum and is chaired by the Secretary of the federal Attorney-General's Department and comprises chairpersons and executive officers of state emergency management committees and the President of the Australian Local Government Association. The AEMC's Australian Tsunami Working Group (ATWG) aims to develop a tsunami emergency management preparedness strategy for Australia consistent with an all-hazards framework.

The inaugural meeting of the ATWG, held in Perth between 30 November and 2 December 2005, addressed ATWG governance issues and strategic implementation issues for the community awareness, education and training elements of the Australian Tsunami Warning System. The remainder of the meeting was devoted to a workshop on tsunami risk and impact and the role of inundation modelling for emergency management planning and response capabilities. The workshop was facilitated by Emergency Management Australia and Geoscience Australia.

Geoscience Australia's scientists demonstrated detailed tsunami impact modelling work conducted in collaboration with the West Australian Fire and Emergency Services Authority. The presentation demonstrated the potential of detailed impact modelling to form the basis for emergency management response plans and capacity testing. This message was reinforced by Tony Pearce who chaired the AEMC's Catastrophic Disasters Working Group which used similar models, based in part on Geoscience Australia's research, to help assess Australia's capacity to respond to catastrophic disasters. The international guest speaker was George Crawford from the Washington State Emergency Management Division, who demonstrated how modelling is a core part of his program.

There was unanimous acknowledgment of the usefulness of detailed impact modelling for mitigating the effects of tsunamis. However, the biggest hurdle to detailed impact modelling is the non-availability of reliable, high-resolution bathymetry and elevation data. Consequently, the state agencies and Geoscience Australia will conduct a first pass analysis to identify which communities are most at risk from tsunami, with each jurisdiction then investigating the availability of data to support detailed inundation modelling. Once modelling has been completed emergency services agencies will work closely with the communities to help develop

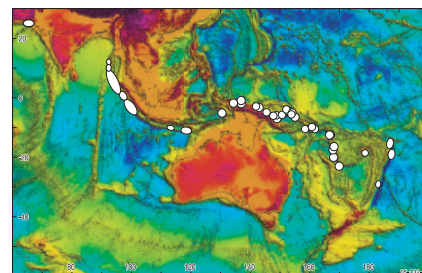

effective mitigation and response options. Geoscience Australia will also develop a set of guidelines for the state agencies outlining the requirements for the collection of bathymetry and elevation data. These guidelines will assist the exchange of data between agencies as well as providing guidance for third parties in the collection of data.

**For more information phone
Jane Sexton on +61 2 6249 9841
(email jane.sexton@ga.gov.au)**

Related articles/website

Final report and presentation by Working Group on Tsunamis, The Prime Minister's Science, Engineering and Innovation Council
www.dest.gov.au/sectors/science_innovation/science_agencies_committees/prime_ministers_science_engineering_innovation_council/meetings/fourteenth.htm

New Chief for Minerals Division

Dr James Johnson has recently joined Geoscience Australia as the new Chief of the Minerals Division. James brings to the position a wealth of experience in mineral exploration, mine geology, research management and leadership. He was also a member of the Executive Research Committee of the Predictive Mineral Discovery Cooperative Research Council (pmd*cr).c).

After graduating with First Class Honours from Sydney University in the mid-1980s, James joined Western Mining Corporation (WMC) at their nickel mines in Kambalda before moving to Olympic Dam as a Mine Geologist. He then undertook a PhD on Olympic Dam at the Australian National University. This focussed on identifying metal sources and was followed by two years of post-doctoral studies at the University of Ottawa in Canada studying Australian and Canadian deposits similar to Olympic Dam (iron oxide, copper-gold).

In 1995 James and his wife returned to Perth and he spent two years exploring for Proterozoic iron oxide, copper-gold deposits in the Gascoyne Province. Following a move to Norseman as Senior Exploration Geologist, he transferred to St Ives gold mine at Kambalda in 1999 to manage regional exploration then exploration on the St Ives core tenement and ultimately the company's Geology Department. As Geology Manager at St Ives he supported funding for external research and is aware of the high-calibre research available in Australia.

This period spanned the sale of WMC's gold assets to Gold Fields Limited. He returned to Perth with Gold Fields in 2005 as Regional Geologist managing exploration projects in China and Victoria.



James considers his move to Geoscience Australia as an opportunity to have an impact on geosciences on a national scale. Following a familiarisation with the diversity of current Geoscience Australia projects, James sees his main challenges as ensuring the Minerals Division's programs are relevant and applicable to exploration in Australia, particularly undercover exploration, and working hard to promote Australia as an investment destination.

Exploring the blind canyons off southwest Australia

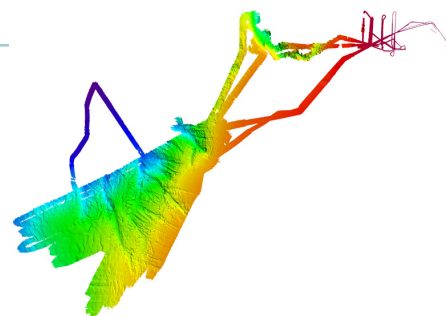

Geoscience Australia and the federal Department of the Environment and Heritage recently completed a survey to explore blind submarine canyons off southwest Australia. The survey, which was conducted during September and October 2005 on Australia's National Facility research vessel *Southern Surveyor*, documented the geological and biological transitions of different seabed geomorphic habitats as well as investigating the Mentelle Basin and assessing this frontier area for petroleum potential.

To date there has been limited knowledge of Australia's deep-water benthic (seafloor) habitats. To gain a better understanding of these environments the survey acquired swath images which allow the topography of the seafloor to be mapped in detail and provide information on seafloor characteristics. The survey acquired comprehensive coverage of the Perth Canyon by using high-resolution swath imagery. Benthic biota found in the Perth Canyon—a well-developed shelf-intruding canyon—were compared with those found in a nearby blind canyon which is confined to the continental slope.

Blind canyons are potentially unexplored habitats and could be home to different varieties of fauna. They are also the most numerous type of canyon on the Australian margin. Investigating the differences in seabed environments in this way indicates the diversity of benthic habitats according to variations in geomorphology. Geoscience Australia scientists also identified two previously unknown canyons, and a 75 km² slump block at the head of the Geographe Canyon. The slump block is important because of its tsunami-generating potential.

The survey achieved several firsts including capturing the first images of the seabed below 2000 metres in this region and the first rock samples ever recovered from the Mentelle Basin. The survey also collected the most comprehensive shallow seismic coverage of the area. Core samples taken from the basin will provide insights into the sedimentation history of deep-water deposition in canyons and surrounding areas. The scientific data collected during this survey will provide an improved understanding of the geology and seafloor of the Mentelle Basin and will assist in maintaining its biodiversity and identifying its petroleum potential.

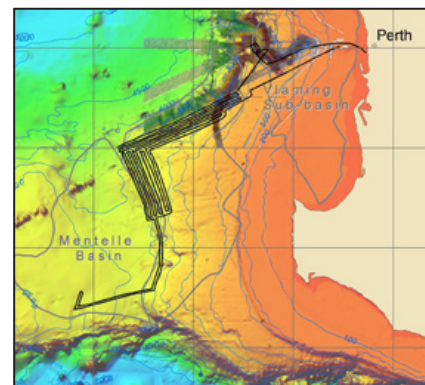

Analysis of data collected during the survey is currently underway and final results are expected later this year.

For more information phone Andrew Heap on +61 2 6249 9790 (email andrew.heap@ga.gov.au) ☐

Successful launch of ALOS satellite



The Advanced Land Observing Satellite (ALOS), also known as 'Daichi', launched by the Japan Aerospace Exploration Agency (JAXA) on 24 January 2006 is set to provide high quality, low cost earth observation data to the Australian government within the next six months.

A five year Memorandum of Understanding, signed between Geoscience Australia and JAXA in 2005, means that ALOS data can be used to benefit Australia in areas such as topographic mapping, disaster and environmental monitoring, climate change studies and mineral exploration.

Many Australian agencies currently rely on Landsat 5 satellite data to deliver their programs but are also seeking higher-resolution imagery. ALOS is expected to complement the Landsat data, as well as provide a limited back-up service in the event of a Landsat malfunction.

ALOS carries two optical imaging instruments with spatial resolutions of 2.5 metres and 10 metres as well as a radar imaging instrument with a resolution of 10 metres to 100 metres. The new satellite is designed for a three year life span, with enough fuel to last for five years.

ALOS data is expected to be available to users by September following the successful completion of the initial calibration and validation tests. A limited range of products may be available by June for test and validation purposes.

Geoscience Australia previously acquired data from the ALOS predecessor, the Japanese Earth Resources Satellite (JERS-1) which ended its mission in 1998.

For more information visit Geoscience Australia's ACRES web page (www.ga.gov.au/acres/) ☐

Product News

Paterson Province GRAVITY DATA RELEASED

New gravity data covering the Paterson Province of Western Australia were released in December 2005. This new gravity dataset will be a valuable tool in assessing the mineral potential of the region.

The data were acquired in a gravity survey conducted in 2005 and managed by Geoscience Australia on behalf of the Geological Survey of Western Australia.

The survey took in a large area of the Paterson Province in the Great Sandy and Little Sandy deserts, about 1250 kilometres north of Perth. The survey area, accessed via the town of Marble Bar, is covered by northwesterly trending sand dunes and includes the significant Telfer and Nifty gold and copper mines.

Daishsat Pty Ltd performed gravity acquisition and data processing between August and October 2005. The survey used Scintrex CG3M/CG5 and LaCoste Romberg gravity meters, and geodetic-grade Ashtech Z12 GPS receivers to obtain position and ground elevations. A Bell-47 Soloy helicopter transported the operator and gravity meter between stations.

The data were acquired at a station spacing of 2.5 x 2.5 kilometres, with a small block acquired at 2 x 2 kilometres, on a survey grid oriented at approximately 330 degrees (NNW). A total of 4528 new gravity stations are now available over the survey area—a vast improvement on the old coverage of only 256 stations spaced at about 10 x 10 kilometres.

The data have been incorporated into the Australian National Gravity Database. The point-located and gridded data for the Paterson survey can be obtained free online using the GADDS download facility. An operations report can be downloaded from the Geophysical Acquisition and Databases web page.

For more information phone Murray Richardson on +61 2 6249 9229 (email murray.richardson@ga.gov.au) 

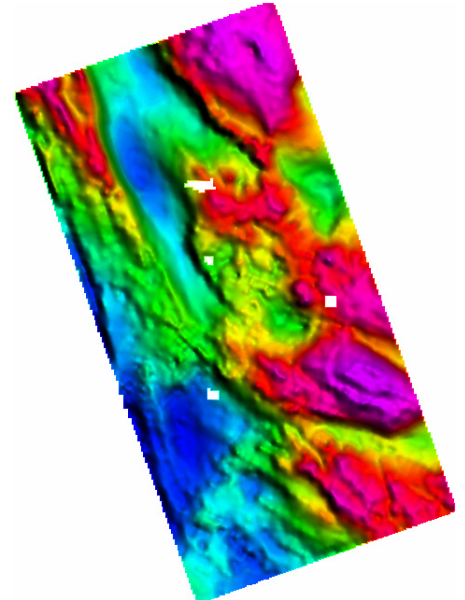

Related websites

Geophysical archive data delivery system:
www.geoscience.gov.au/gadds
Operations report:
www.ga.gov.au/minerals/research/methodology/geophysics/acquisition.jsp#reports

1:250 000 scale raster maps now online

Geoscience Australia's TOPO-250K Raster maps are now available online. The 1:250 000 scale national topographic data is a raster version of Geoscience Australia's GEODATA TOPO-250K Series 2 national fundamental vector data. The data are available under the Australian Government Spatial Access and Pricing Policy.

This free data download facility is expected to be popular with commercial and government GIS users and map producers. The release will significantly benefit government and other users in regional planning, agriculture, emergency management, environment, tourism and map-based presentations. Commercial mapmakers will be able to use the raster data (an alternative to vector data) to develop products for tourism and other markets.

TOPO-250K Raster data is the foundation for Geoscience Australia's NATMAP Raster products. These are already popular in the recreational and commercial markets, and significant demand is expected to continue.

The two packaged versions—NATMAP Raster (four CDs) and NATMAP Raster Premium (two DVDs) 2005 releases—are inexpensive and particularly suited to recreational and occasional users without GIS capabilities, as they include viewing software, nationwide topographic maps at various scales, a satellite image and other features.

For more information phone the Geoscience Australia Sales Centre on Freecall 1800 800 173 (within Australia) or +61 2 6249 9966 (email mapsales@ga.gov.au) 



Geology of Eastern Australia available as single dataset

Outcrop geology data covering all of the eastern states of Australia from Cape York to Tasmania at 1:1 million scale is now available in a single dataset from Geoscience Australia. The dataset contains over 3500 geological units all of which are registered in the Australian Stratigraphic Units Database and are attributed with the appropriate 'Stratno'. At approximately 650 Megabytes, the dataset is only available on CD or DVD through the Geoscience Australia Sales Centre. The data was released in September 2005 as four state-wide, edge-matched products: Queensland; New South Wales; Victoria (2nd edition); and Tasmania (2nd edition: see *AusGeo News* 79). These state-wide products continue to be available on CD or can be downloaded free of charge from the Geoscience Australia website.

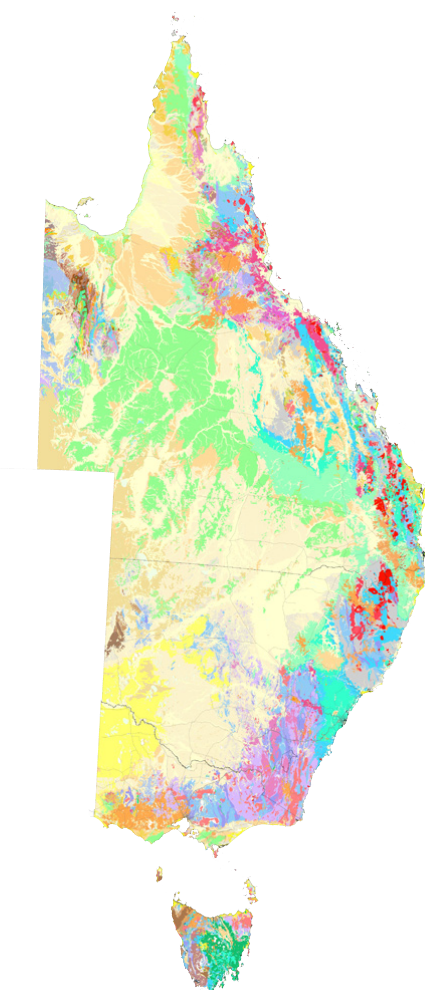
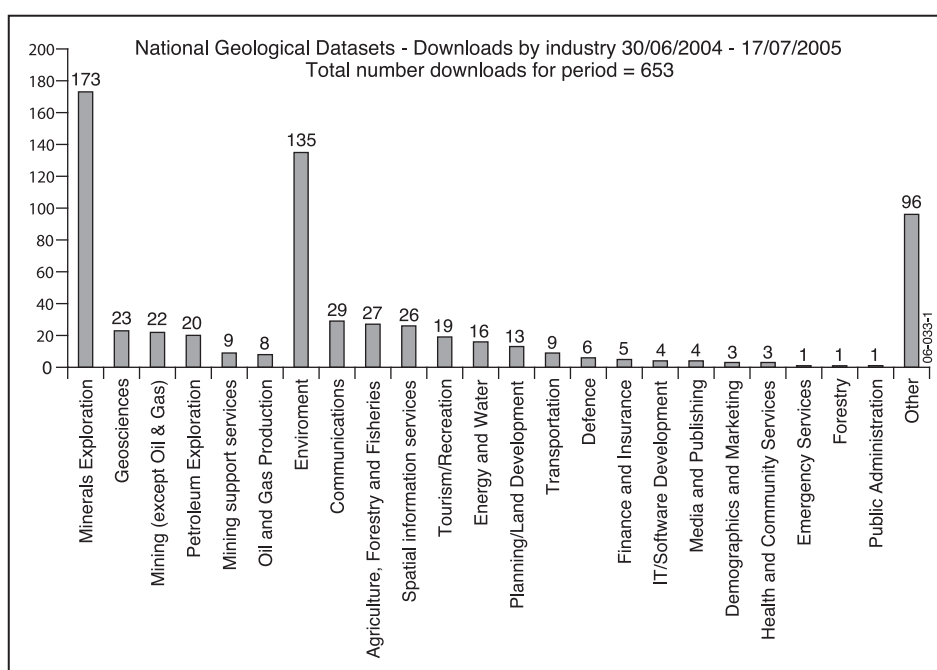

◀ **Figure 1.** Downloads of National Geological Datasets by industry 30 June 2004 to 17 July 2005.

Analysis of download statistics for the initial releases of Tasmania (1st edition), Victoria (1st edition), South Queensland, and NW Queensland over 12 months to July 2005 (figure 1) indicates a diverse client base with two industry sectors dominating: Minerals Exploration (27%) and Environment (21%). Total downloads by sectors directly involved in geoscience activities including Minerals Exploration, Mining, and Oil and Gas Exploration/Production, amounted to about 40% of all downloads. A further 20% of downloads were by the Communications, Agriculture-Forestry and Fisheries, Spatial Information Services, Tourism/recreation, Energy and Water, and Planning/Land development sectors. Over the sixteen months to September 2005 there were around 700 downloads of these early versions. The new or updated state-wide datasets have proved more popular with more than 500 already downloaded since their release last September.

Compilation work on the surface geology of both the Northern Territory (~70% compiled) and South Australia (~50% compiled) is well advanced. Release of version 1 products for these jurisdictions is expected by December 2006 after review by the respective territory and state geological surveys. Compilation work on the eastern part of Western Australia will commence in April.

For more information phone Alan Whitaker on +61 2 6249 9702 (email alan.whitaker@ga.gov.au). To order copies of the CDs or DVDs phone Freecall 1800 800 173 (in Australia) or +61 2 6249 9966 (email mapsales@ga.gov.au) 📠

Related articles/websites

AusGeo News 79 📄
 (New 1:1 million Geology of Eastern Australia available)

Free download
www.ga.gov.au/products

Events

Students experience geoscience

Over 70 students attended two half-day workshops developed and presented by Geoscience Australia staff during January as part of the National Youth Science Forum. Under the guidance of a team of Geoscience Australia geoscientists, students used a range of datasets including geochemical, gravity and magnetic data, laboratory studies and geographic information systems to locate a 'new' gold deposit in the remote Burtville region of Western Australia. The exercise scenario allowed the students to simulate a typical Geoscience Australia working environment, where team work and the integration of disparate datasets were emphasised. The students also took the opportunity to question the Geoscience Australia scientists about their own career paths and choices. Most of the students have interests in chemistry, and since the workshops have a strong emphasis on physics, they left with a positive view of the breadth of the geosciences.

The National Youth Science Forum is a two-week program held in Canberra in January each year. The program is designed for students moving into Year 12, who wish to follow careers in science, engineering and technology. It offers students an introduction to research and researchers and an opportunity to develop their communication and interpersonal skills. Presentations and workshops are given by government and industry organisations to provide an insight into career pathways, and how science and engineering contribute to the strength of the nation through publicly funded projects and industrial research and development.

For more information phone Kate List on +61 2 6249 9571 (email kate.list@ga.gov.au)

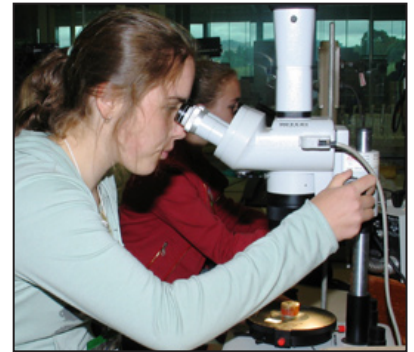

14th NSW Coastal Conference

Geoscience Australia participated in the 14th NSW coastal conference which was held at Narooma in the Eurobodalla Shire on the south coast of NSW between 8 and 11 November 2005. The conference is an annual event and attracts delegates from government, academia, the community and the private sector. It was sponsored by the NSW Department of Infrastructure, Planning & Natural Resources, Eraring Energy, GHD Services Pty Ltd and The Catchment Management Authorities of Coastal NSW.

The five conference themes were: the environment, planning, community, science and the economy. There were about 250 delegates who heard 40 presentations and viewed 10 poster displays over the three days. One poster outlined the formation of the Sapphire Coast Marine Discovery Centre at Eden in the Bega Valley Shire (Sapphire Coast). The centre will have three elements: a Research facility, an Education Centre and a Visitor Centre and is planned to become a world class facility within 10 years.

Delegates also had the opportunity to participate in excursions including presentations on the Narooma Structure Plan which is a model for managing coastal growth in small coastal towns, the South Coast Shorebird Recovery program, the significance of healthy coastal ecosystems and water quality as they relate to the local economy (including recreational and commercial fishing, aquaculture and tourism) as well as an indigenous perspective on the coast from representatives from the Yuin Country.

Geoscience Australia's representative presented a paper on 'Sustainable Nitrogen Loads and Water quality in NSW Estuaries'. The paper reported on the amounts of nitrogen that can be added to estuaries of different morphologies and flushing regimes which are unlikely to result in eutrophication (see 'Clean or green – nitrogen in temperate estuaries' in this issue). This paper and the other conference papers and resolutions are presented at the conference website.

Narooma is settled around Wagonga Inlet and Montague Island rises from the sea-mist a few kilometres offshore. The accompanying image shows Wagonga Inlet which is a wave dominated estuary classified to be in a 'modified' condition by the National Land & Water Resources Audit. Prominent in the picture are the central basin, the training walls at the entrance and the extensive flood tidal delta formed by sand moving into the estuary from the sea.



For more information phone David Heggie on +61 2 6249 9589 (email david.heggie@ga.gov.au)

Related websites/articles

NSW Coastal Conference website
www.esc.nsw.gov.au/coastal

Sapphire Coast Marine Discovery Centre
www.edenmarinediscovery.org.au

National Land and Water Resources audit
www.nlwra.gov.au
www.environment.gov.au/atlas

Australian estuaries
www.OzEstuaries.org

Events Events Calendar 2006

AAPG Annual Meeting

American Association of Petroleum Geologists Annual Meeting and Exhibition

9 to 12 April

Houston, Texas

Contact: AAPG Convention Department, PO Box 979, Tulsa Oklahoma 74101-0979 USA

phone +1 918 560 2617

fax +1 918 560 2684

e-mail convene2@aapg.org

www.aapg.org

South Australian Resources & Energy Investment Conference

1 to 3 May

Hilton Adelaide

Contact: Paydirt Media Pty Ltd, PO Box 1589, West Perth, WA 6872

phone +61 8 9321 0355

fax +61 8 9321 0426

e-mail samantha@paydirt.com.au

www.saresourcesconf.com

APPEA Conference and Exhibition

Australian Petroleum Production and Exploration Association

7 to 10 May

Gold Coast Convention and Exhibition Centre

Contact: Vicki O'Gorman, APPEA Limited, GPO Box 2201, Canberra ACT 2601

phone +61 2 6247 0960

fax +61 2 6247 0548

e-mail vogorman@appea.com.au

www.appea.com.au

SEG 2006 Conference

Society of Economic Geologists

14 to 16 May

Keystone, Colorado

Contact: Society of Economic Geologists, 7811 Shaffer Parkway, Littleton, Colorado 80127-3732 USA

phone +1 720 981 7882

fax +1 720 981 7874

e-mail seg2006@segweb.org

www.seg2006.org/

AMEC Congress 2006

Association of Mining and Exploration Companies

7 to 9 June

Burswood Convention Centre and Resort

Contact: AMEC, PO Box 545, West Perth, WA 6872

phone 1300 738 184

fax 1300 738 185

email pdteam@amec.org.au

www1.amec.org.au/

Australian Earth Sciences Convention 2006

18th Australian Geological Convention & Australian Society of Exploration Geophysicists 18th Geophysical Conference and Exhibition

2 to 6 July

Melbourne Exhibition and Convention Centre

Contact: The Meeting Planners, 91-97 Islington Street Collingwood Vic 3066

phone +61 3 9417 0888

fax +61 3 9417 0899

email

earth2006@meetingplanners.com.au

www.earth2006.org.au/

Diggers and Dealers Forum 2006

7 to 9 August

Goldfields Arts Centre, Kalgoorlie

Contact: Suzanne Christie, Diggers and Dealers Mining Forum, PO Box 979, West Perth, WA 6872

phone +61 8 9481 6440

fax +61 8 9481 6446

email admin@diggersnddealers.com.au

www.diggersnddealers.com.au/

16th Annual V M Goldschmidt Conference 2006

European Association for Geochemistry, Geochemical Society and Geological Society of Australia

27 August to 1 September

Melbourne Exhibition and Convention Centre

Contact: Tour Hosts Pty Ltd, GPO Box 128, Sydney NSW 2001

phone +61 2 9265 0700

fax +61 2 9267 5443

email goldschmidt2006@tourhosts.com.au

www.goldschmidt2006.org/

AAPG International Conference and Exhibition

American Association of Petroleum Geologists

5 to 8 November

Perth Convention and Exhibition Centre

Contact: AAPG Convention Department, PO Box 979, Tulsa Oklahoma 74101-0979 USA

phone +1 918 560 2617

fax +1 918 560 2684

e-mail convene2@aapg.org

www.aapg.org

AusGeoRef

Australian Geoscience References

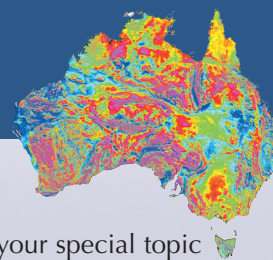

Find

Information about:

- Australian geoscience
- Papers from Australian geoscience conferences and journals
- The latest research in your particular field
- An Australian geographic location or a geological feature

Annual subscription costs start from \$US95.00.

Try the 30 day free trial (<http://www.ausgeoref.org>)

For more information phone + 61 2 6249 9567
or e-mail Geoscience Australia's Library.
(Reference.Library@ga.gov.au)

Create

- A search on your special topic
- A customised bibliography
- An Alert profile for your particular field
- A document request



Australian Government

Geoscience Australia

in
collaboration
with

